

PERFORMANCE ANALYSIS OF A DOMESTIC REFRIGERATOR USING VARIOUS ALTERNATIVE REFRIGERANT

¹ Sarthak Thakar, ² R.P.Prajapati

¹PG Student, ²Assitant Professor

^{1,2} Thermal Engineering Department, Sal Institute Of Technology & Engineering Research, Ahemadabad
sarthakmthakar@gmail.com, thakarsarthak@gmail.com

Abstract — This work presents the development process of Refrigerator test ring and then carry- out the performance analysis of domestic refrigerator. The experiment platform which is called refrigerator test ring will be developed from refrigerator model. Performance of refrigerator also depends on inlet and outlet condition of each components. So in this research work refrigerator test ring will be developed and obtain performance of domestic refrigerator in term of Refrigeration Capacity, Compressor Work and Coefficient of Performance (COP) by determining two important parameter during operating condition which are temperature and pressure. So carry out this project I use different alternative refrigerant and find the data and compare the data to each other and then find the alternate of R 134a.

Index Terms — energy harvestation, generating electrical power.

I. INTRODUCTION

What is Refrigeration?

Refrigeration is definite as the procedure of removing heat from a body or enclosed space so that the temperature first lowered and then maintained at level below the temperature of surrounding. The equipment used to maintain the required temperature is called refrigerating equipment.

A. Types of Refrigeration system

There are two types of refrigeration system

1. Vapour Compression Refrigeration system (VCRS)
2. Vapour Absorption Refrigeration system (VARS)

B. VCRS system

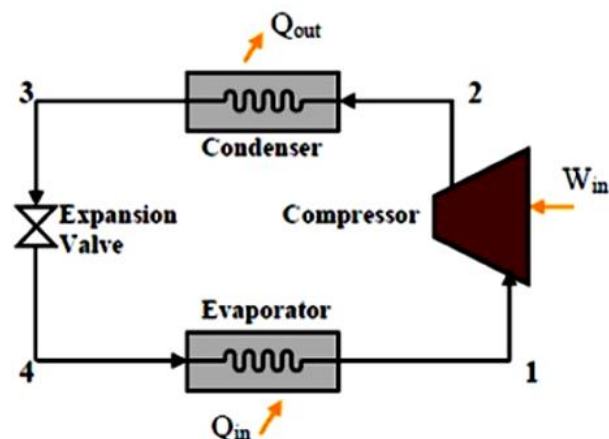

Fig. 1.1 VCRS system

The above diagram shows the refrigeration circuit. The Main four processes are Evaporation, Compression, Condensation and Expansion.

The procedure starts with vaporization of the refrigerant in the evaporator. This is complete at point 2. Compression is used to elevate the pressure of the refrigerant, point 3, so that it can condense at a higher temperature. When all the vapour has condensed, point 4, the pressure is reduced in an expansion device, and the refrigerant is returned to its original condition 1.

C. Components of Refrigeration system

1. Compressor
2. Condenser
3. Expansion valve
4. Evaporator

Compressor

It compresses the refrigerant. The compressor collect low pressure gas from the evaporator and converts it to high pressure gas. As the gas is compressed, the temperature rises. The hot refrigerant gas then flows to the condenser.

II. CONDENSER

A condenser is a device or unit used to condense a core from its fizzy to its fluid state, by cooling it. In so doing,

the latent heat is given up by the substance, and will transfer to the condenser coolant.

III. EXPANSION VALVE

Its task is to meter the amount of refrigerant to be supplied to evaporator and to reduce the pressure up to evaporator pressure such that fluid can vaporise at the evaporator coil.

IV. EVAPORATOR

An evaporator is used in an air-conditioning system to allow a compressed cooling refrigerant, to evaporate from liquid to gas while absorbing heat in the process. It can also be used to remove water or other liquids from mixtures.

A. Thermodynamic Analysis of VCRS

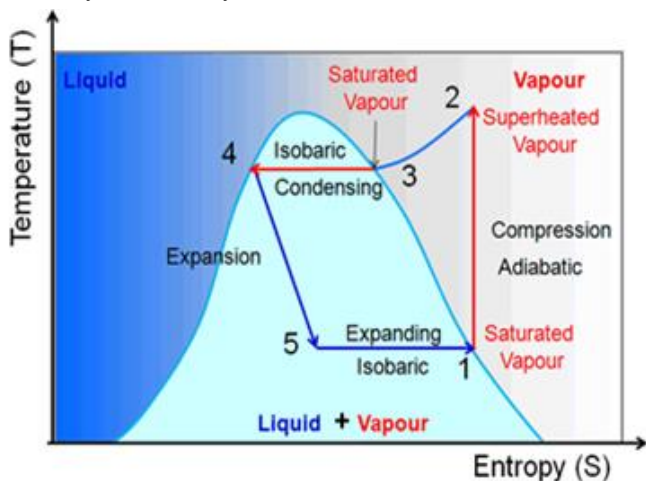

3: Isobaric heat rejection in condenser
Process 3-4: Isentropic expansion of saturated liquid in expansion device
Process 4-1: Isobaric heat extraction in the evaporator.

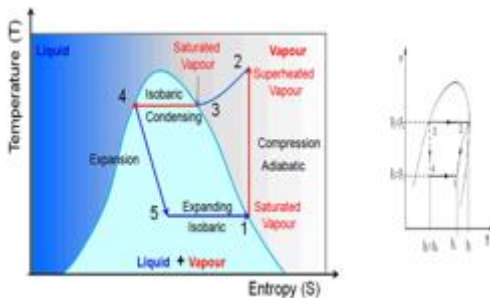

Fig. 1.3 P-h diagram of VCRS system

Expansion is a constant enthalpy process. It is drawn as a vertical line on the above P-h diagram. No heat is absorbed or rejected during this expansion, the liquid just passes through a valve, like water coming out of a tap. The difference is, that because the liquid is saturated at the start of expansion by the end of the process it is partly vapour. Point 1 is inside the curve and not on the curve as described in the Evaporation process. The refrigerant at the beginning of the vaporization is already

partly evaporated. This depends on the shape of the curve, and the start and end pressures.

The Compression process is shown as a curve. It is not a constant enthalpy process. The energy used to compress the haze turns into heat, and increases its temperature. This tends to raise the temperature of the vapour, making point 3 move further into the superheated part of the diagram as compression progresses. Point 3 is outside the curve as described in the Compression process. This means that before Condensation can start, the vapour has to be cooled down.

Domestic Refrigerator

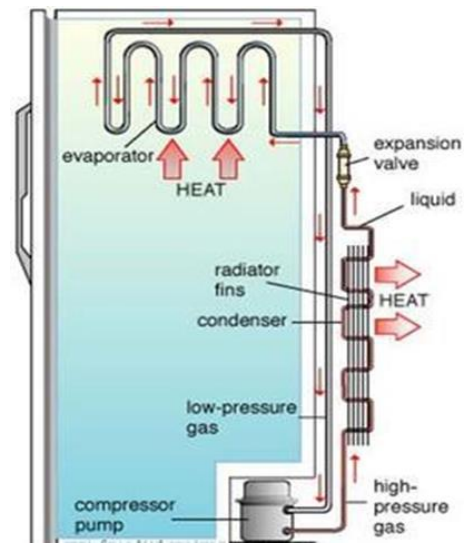

Fig. 1.4 Domestic Refrigerator

B. Internal Parts of the Domestic Refrigerator

The internal parts of the refrigerator are ones that carry out actual working of the refrigerator. Some of the internal parts are located at the back of the refrigerator, and some inside the main compartment of the refrigerator.

1)Refrigerant:The working body used to produce refrigeration is called the refrigerant. The refrigerant flows through all the internal parts of the refrigerator. It is the refrigerant that carries out the cooling achieve in the evaporator. It absorbs the heat from the core to be cooled in the evaporator (chillier or freezer) and throws it to the atmosphere via condenser. The refrigerant keeps on recalcuating through all the inner parts of the refrigerator in cycle.

2)Compressor:The compressor is located at the back of the refrigerator and in the bottom area.The compressor sucks the refrigerant from the evaporator and discharges it at high pressure and temperature. The compressor is driven by the electric motor and it is the major power consuming devise of the refrigerator. In most of the refrigerator reciprocating and hermitically sealed compressor are used.

3)Condenser:In refrigerator air-cooled condenser is used since, the constriction of air-cooled condenser is very simple.

The condenser is the thin coil of copper tubing situated at the back of the refrigerator. The refrigerant from the compressor come in the condenser where it is cooled by the atmospheric air thus losing heat absorbed by it in the evaporator and the compressor. To increase the heat transfer rate of the condenser, it is finned outwardly.

4)Expansion valve or the capillary::The refrigerant leaving the condenser come in the expansion devise, which is the capillary tube in case of the domestic refrigerators. The capillary is the thin copper tubing made up of number of turns of the copper coil. When the refrigerant is passed through the capillary its pressure and temperature drops down suddenly. And it is a constant enthalpy process.

5)Evaporator or freezer: The refrigerant at very low pressure and temperature enters the evaporator or the freezer. The evaporator is the heat exchanger made up of several turns of copper or aluminium tubing. In domestic refrigerators the plate types of evaporator is used as shown in the figure above. The refrigerant absorbs the heat from the body to be cooled in the evaporator, gets evaporated and it then sucked by the compressor. This cycle keeps on repeating.

6) Temperature control devise or thermostat: To control the temperature in the interior the refrigerator here is thermostat, whose sensor is connected to the evaporator. The thermostat setting can be done by the round knob in the refrigerator compartment. When the set temperature is reached inside the refrigerator the thermostat stops the electric supply to the compressor and compressor stops and when the temperature falls below certain level it restarts the supply to the compressor.

7)Defrost system: The defrost system of the refrigerator helps removing the excess ice from the surface of the evaporator. The defrost system can be operated physically by the thermostat button or there is automatic organism comprising of the electric heater and the timer.



Fig. 1.5 External Parts of Domestic Refrigerator

Now let us see the external parts of the refrigerator.

The exterior parts of the refrigerator are: freezer compartment, thermostat control, refrigerator compartment, crisper, refrigerator door compartment, light switch etc.

External Visible Parts of the Refrigerator

1) Freezer compartment: The food substance that are to be set aside at the freezing temperature are store up in the freezer compartment. The temperature here is below zero degree. Celsius so the water and many other fluids chill in this compartment. If you want to make ice- cream, ice, freeze the food etc. they have to be kept in the freezer section.

2)Thermostat control: The thermostat control comprises of the round knob with the temperature scale that help setting the required temperature inside the refrigerator. Proper Setting of the thermostat as per the requirements can help saving lots of refrigerator electricity bills.

3)Refrigerator compartment: The refrigerator section is the largest part of the refrigerator. Here all the food substance that are to be maintained at temperature above zero degree Celsius but in cooled condition are kept. The refrigerator compartment can be divided into number of smaller shelves like meat keeper, and others as per the requirement.

4)Crisper: The highest temperature in the refrigerator compartment is maintained in the crisper. Here one can keep the food items that can stay fresh even at the medium temperature like fruits, vegetables, etc.

5) Refrigerator door compartment: There are number of smaller subsections in the refrigerator main door compartment. Some of these are egg compartment, butter, dairy, etc.

6) Switch: This is the small button that operates the small light inside the refrigerator. As soon the door of the refrigerator opens, this switch supplies electricity to the bulb and it starts, while when the door is closed the light from the bulb stops. This helps in starting the internal bulb only when required.

Properties of refrigerants:

Refrigerant should be required following properties :

- It should be non-hazardous, non-flammable and non-corrosive.
- It should have low condensing pressure and the evaporative pressure slightly higher than the atmospheric pressure. It implies that it should low pressure ratio.
- It should have high latent heat of vaporization
- It should have high critical pressures and temperature.
- It should have low boiling point and freezing point.
- It should have low viscosity and
- die-electric strength.
- Specific volume should be suitable to the application.

- It should not be miscible with lubricate oil.
- The leak finding should be easy.
- It should be cheap.

2. R-600
3. R-290
4. R-152
5. R-600a
6. R-436a
7. R600/R 290(50/50)
8. R134/R290(50/50)
9. R134/R600(50/50)

Chemical refrigerants are assigned an R number which is determined systematically according to molecular structure.

In my project I use the following refrigerant and also blend of different refrigerant

1. R-134a

Refrigerant (category)	Chemical Formula	Normal boiling point	Critical Temperature (°C)	ODP	GWP	Safety group
R 134a	CF ₃ CH ₂ F	-26.07	101.6	0	1380	A1
R 152a	CH ₃ CHF ₂	-24.2	113.5	0	20	A1
R 290	C ₃ H ₈	-42.1	96.8	0	20	A3
R 600	C ₄ H ₁₀	-0.56	153	0	20	A3
R 600a	(CH ₃) ₃ CH	-11.67	135	0	20	A3
R600/290(50/50)	C ₄ H ₁₀ +C ₃ H ₈	-21.33	124.9	0	20	A3
R134a/R290(50/50)	CF ₃ CH ₂ F+ C ₃ H ₈	-34.07	99.2	0	20	A3
R 436a		-51.6	78.1	0	600	A3
R134a/R600(50/50)	CF ₃ CH ₂ F+ C ₄ H ₁₀	-13.31	133.25	0	20	A3

Table 1.1 Refrigerant Property

Experiment set up, Methodology:

Refrigerator Model Details

Brand	Whirlpool
Model name/year	DC -5256/2012
Freezer Capacity (liter)	80
Fresh Food Compartment Capacity (liter)	230
Power Rating	160W
Current Rating	0.9A
Voltage	220-240V
Frequency	50Hz
No of door	Single
Compressor	Hermetic - sealed
Refrigerant type	R134a

Table1.2 specification refrigerator

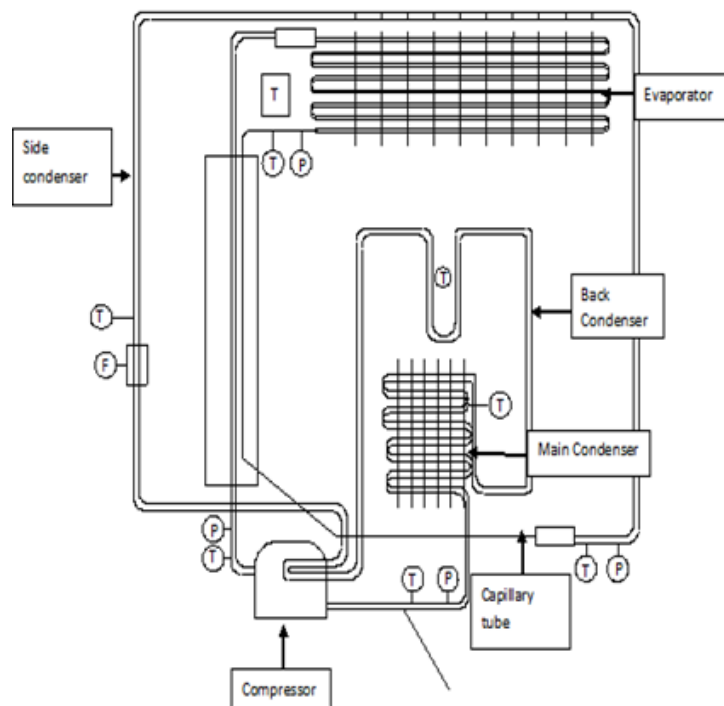

Fig.1.6 Line diagram of experiment

This Section provides the information about the how I was developed the experiment set up and how I will carry out the test procedure the during experiment. First the experiment test ring developed from the refrigerator model. To perform the experiment and develop the test ring 230L refrigerator is selected. and Fig. shows the line diagram of test ring and connection point of pressure and temperature measurement.



Fig1.7 Experiment set up

Now from the experiment test ring there 6 point of temperature measurement and 2 point of pressure measurement. Two point of pressure measurement one of the one point in suction side and another point is in discharge line. The pressure gauge are used for the pressure measurement so compound gauge is fitted on discharge line due to high pressure and vacuum gauge is fitted on suction line due to low pressure as shown in the fig. Now there five point is temperature measurement so one the point of temperature measurement is in evaporator means in the freezer compartment of refrigerator. One point is for the measurement of food storage cabinet. And point is located on the compressor inlet, compressor outlet, condenser inlet and condenser outlet. So now for the temperature measurement digital thermometer are used. Ammeter is also used for the current measurement. So this the procedure of the experiment set up.

Now for the test procedure the evacuation and vacuuming is done by the another compressor. And vacuum is done up to the 25in/hg. This is required for the cleaning of the lines by removing moisture, air and oil. Now after that the refrigerant is charged by the charging system and when the evaporator temp. set at 10oc and 1st I charged the R 134a and collected the data like pressure and temperature every 15 minutes during the running the refrigerator and also collected the data various evaporator temperature. After collecting the data R 134a is removed and refrigerator are charged by another alternative refrigerant like R 290, R 600, R 152a and mixture of the different refrigerant and collected the data. After collecting the experimental data I found different parameter like COP, Refrigerant effect, Compressor power, Volumetric

cooling capacity, mass flow rate , compressor power per ton, compression ratio etc. and then compare this data each other to the refrigerant and find the alternative refrigerant which gives the better performance in compare with R 134a.

So in this way I will be found the best alternative of R 134a.

Calculation

1. Compressor Work done (w) = (h2 – h1) KJ/Kg
2. Refrigerant effect Per Kg (RE) = (h1 – h3) KJ/Kg
3. COP =(Refrigerant effect)/(Compressor work done)
- "4. Mass flow rate = " 3.517/RE
- "5. Compression ratio = " "Discharge pressure " /(Suction pressure)
6. Compressor power per ton = Mass flow rate × Compressor work done
7. Volumetric refrigerant efficiency = RE/(Vg_1)

Notes:- Values of h1, h2, hf3, h4 are calculated by using pressure enthalpy diagram related to the various alternative refrigerant during calculation.

Result and discussion

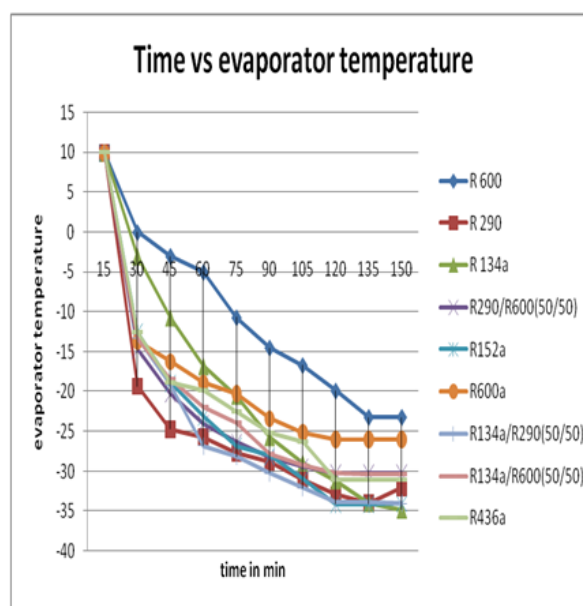

Fig 1.8 Time VS evaporator temperature

As shown in the fig.1.8 at the starting of refrigerator the evaporating temp. of all refrigerant is set to 10oc and as the refrigerator run the evaporator temp. is decrease and after some time it achieve to constant temp. During the starting of 15 minute evaporator temp. drop is high for all refrigerant and among the refrigerants R290 has high temp. drop and R 134a has low temp. drop. As shown in the fig R132a and R152A has achieved highest evaporating temp. after 150 min. and R 600 and R600a has a low evaporating temp.

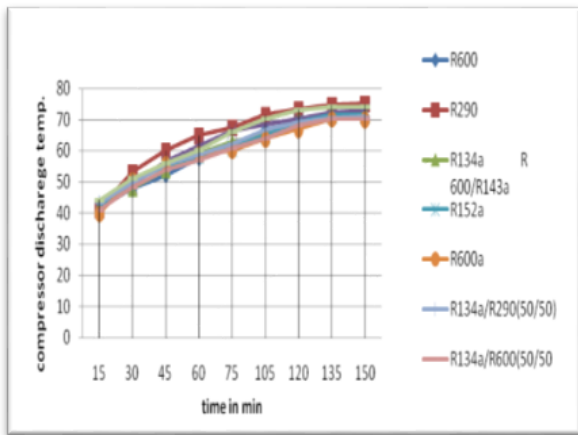

Fig. 1.9 Time VS discharge temp.

As shown in the fig 1.9 the discharge temp. as the starting of refrigerator is low and then increase as the refrigerator and as the time pass the increase rate in discharge temp. is low and after some time it achieve constant temperature. So among the Refrigerant R290 has a highest discharge temp. while R 600 has a lowest discharge temp.

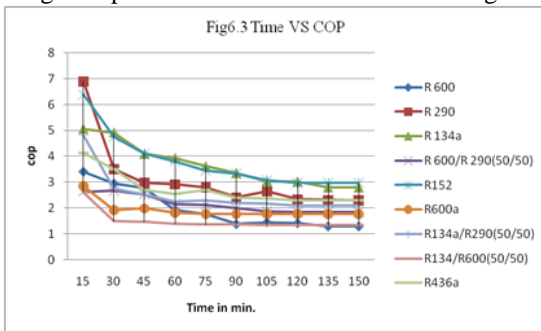

Fig 1.10 Time VS COP

As shown in fig 1.10 the cop at starting of refrigerator is high and R 290 and R152a has a high COP as the starting and as the time goes the cop all refrigerant is start decreasing and reach the constant value. So from the fig is the clear that the COP of R 152a has a high value than another refrigerant and COP of R 290 and R 436a is also near to the COP of R 134a. And the refrigerant R 600 has low COP compare with another refrigerant blend of R 134/R 600an has low COP. Bt from fig. its also say that the R 152 and R 290 give the better performance than another alternate refrigerant. So its possible that the R 152a and R 290 has a better alternate refrigerant.

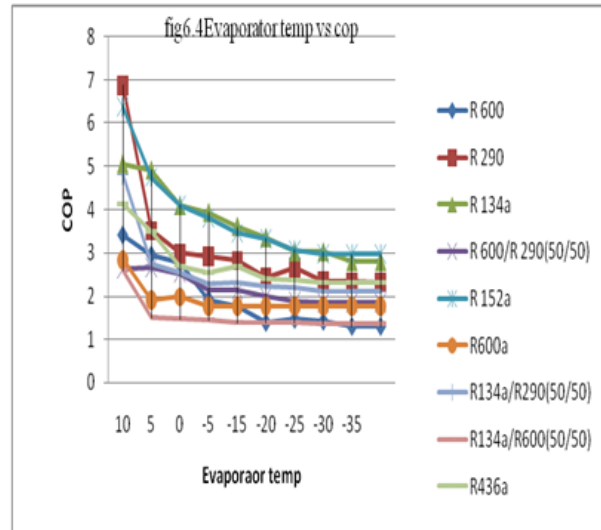

Fig.1.11 Evaporator temperature vs cop

As Shown in fig 1.11 COP decrease as the evaporator temp. is decreasing and R 152a has a high COP at low evaporating temp. and the blend of R 600/134 and R 600 has low COP at low evaporating temp.

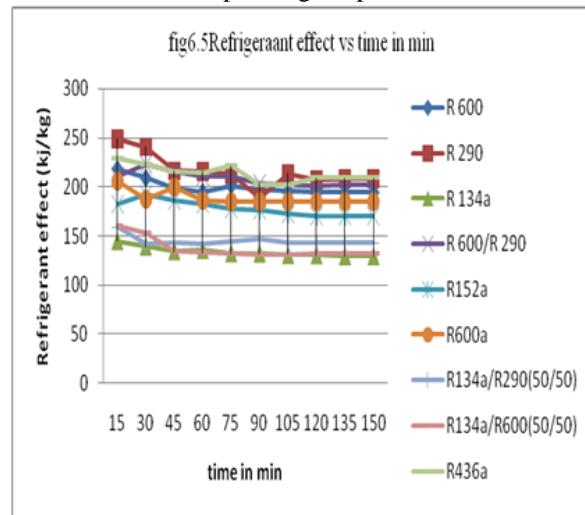

Fig 1.12 Refrigerant effect vs time in min

As shown in the fig at starting of the time the refrigerant is high and then it is start decreasing as the time pass away and one time refrigerant effect is become constant it is due to the setting temp. difference in the cabinet . Now from fig is clear that the refrigerant effect of R 290 has high value than any another refrigerant . But at a same time the refrigerant effect is low for R 134a refrigerant. And from the fig it is also clear that the after some time refrigerant effect has a constant value.

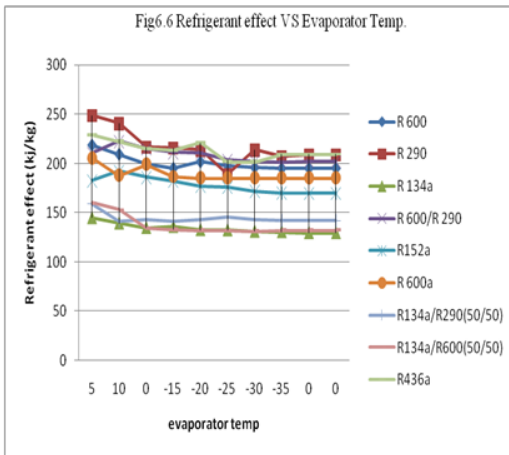

Fig 1.13 Refrigerant effect vs Evaporator temperature

Now from above fig it also clear that the with increasing the evaporator temp. the net refrigerant effect also decrease and achieve the constant value. Refrigerant R 152a and R 134a around the -35oc evaporating temp. low refrigerant effect and also achieve the constant value. While as a same temp. refrigerant R 290 and R 436a high refrigerant effect among the refrigerant.

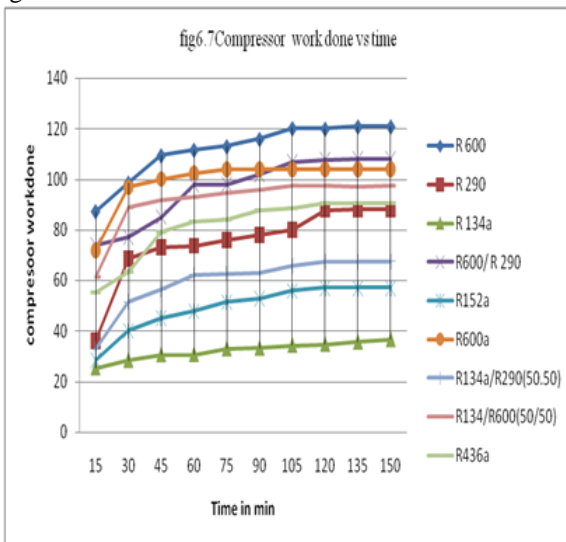

Fig 1.14 Compressor work done vs time

As shown in fig at the starting of the time the compressor work done is low but as the time increase the compressor work done also increase and after some time it become a constant. The rate of increasing the compressor work done is most of the same for all of the refrigerant. From fig it I clear that the compressor work done is low for R 134a and R 152a than another refrigerants . while the work done by the R 290 and R 436a Refrigerant is quite high than R 134a .Now compressor work for refrigerant R 600 is high and also work done for refrigerant R 600a is high than another refrigerant.

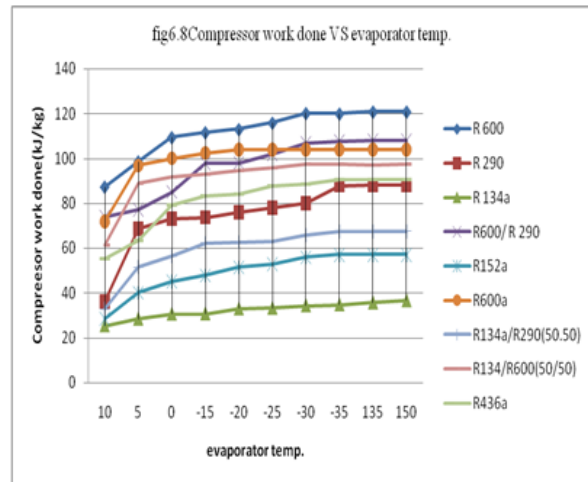

Fig 1.15 Compressor work done vs Evaporator temp

As shown in fig it is clear that the Compressor work increasing as the evaporation temp increase. For R 134a at -35o the compressor work is low than another refrigerant bt work done by the R 152a is near the work done of R 134a. And as the same evaporator temp. work done for R 600 and R 600a is high than another refrigerant.

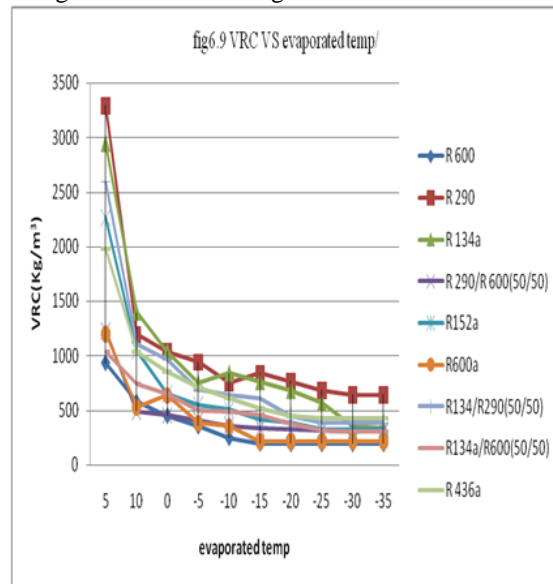

Fig 1.16 VRC vs Evaporated temp

Now fig its shows the variation of volumetric refrigerant capacity to the evaporator temp. from fig.it is clear that the VRC decrease as the evaporated temp. decrease so it is clear that the R 290 has high volumetric refrigerant capacity and R 134a and R 152a has a slightly low volumetric refrigerant capacity as compared to the R290 refrigerant. While as same temp. refrigerant R 600 and R 600a has low volumetric refrigerant capacity than another refrigerant.

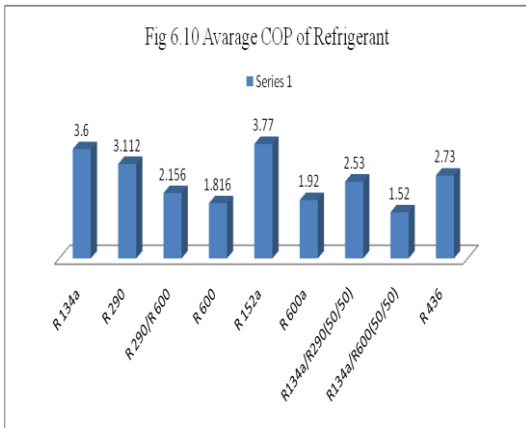

Fig 1.17 Average COP of Refrigerant

Fig. shows the avg. COP of all refrigerant. So from fig, it is clear that the avg. COP of the R 152a is high than another refrigerant and also high than R 134a and also avg. COP of R 290 is near the R 134a. while avg. COP of mixture of R 134 and R 600 is very low. Avg. COP of R 153a is 3.8 and R 134a 3.6 and lowest COP is 1.50 of mixture of R 134a and R 600

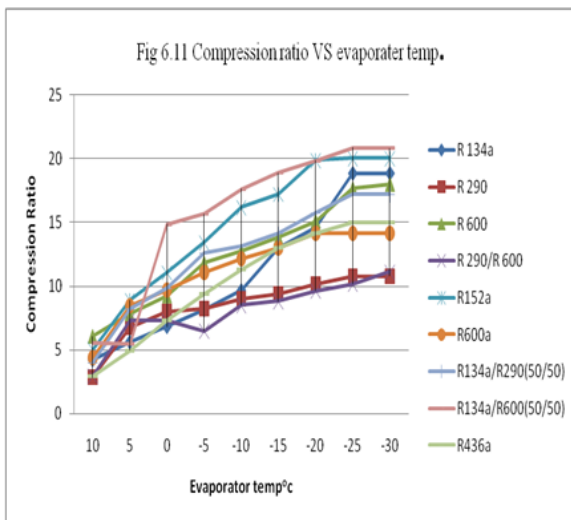

Fig 1.18 Compression ratio vs Evaporater temp

As shown in the fig the compression ratio increase with decrease the evaporator temp. From fig, it is clear that the mixture of R 134a and R 600 and R 600 has high compression ratio and R 134a and R152a has same compression ratio while the Refrigerant R 290 and mixture of R 134a and R 290 has low compression ratio as same temp than any other refrigerant.

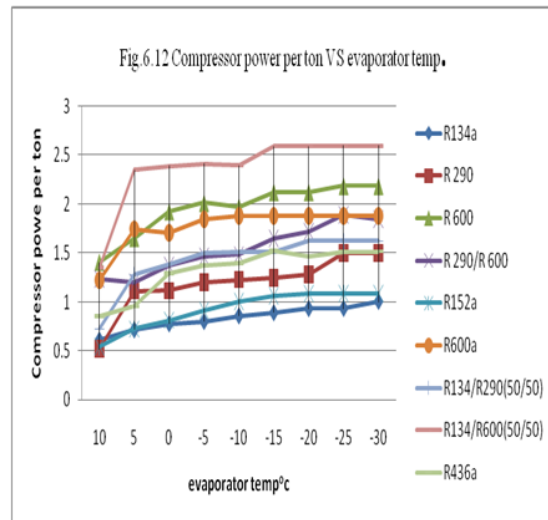

Fig 1.19 Compressor power per ton vs Evaporator temp

As shown in the fig Compressor power per ton is increase as the temp. of evaporator increase. Compressor power per ton is high for the mixture of R134a and R600 and refrigerant R 600. While compressor power per ton is low for R 134a refrigerant and at -30oc temp. compressor power is same for refrigerant R 152a and R 134a

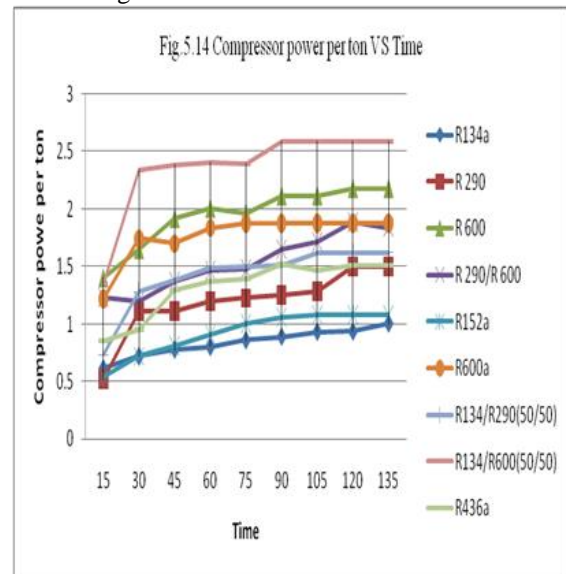

Fig 1.20 Compressor power per ton vs time

As shown in Fig. Compression power per ton is increase as the time of refrigerator running is increase. And after some time it achieve constant value in this fig. after 135 minute running of refrigerator compressor power per ton become constant. For the R 134a and R152a has low compressor power in compare with another refrigerant.

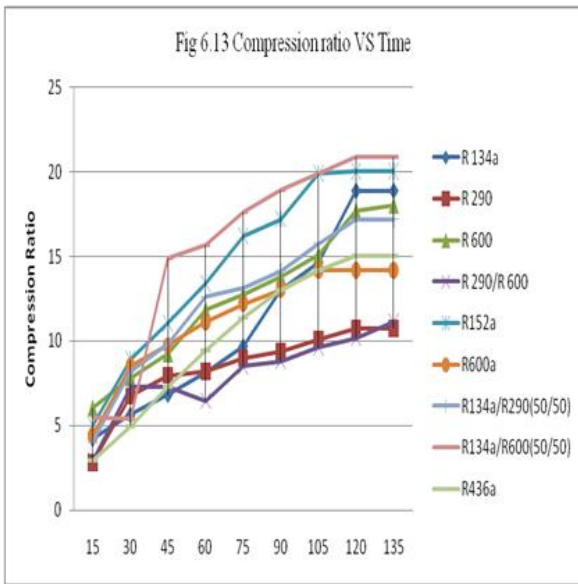

Fig 1.21 Compression ratio vs time

As shown in the fig. compression ratio is increase as running time of refrigerator increase. At the starting of time compression ratio is low for all refrigerant but as the time pass away compression ratio increase due to increase in discharge temp. and after the running of 135 minutue compression ratio become constant. From the fig. it is clear that the compression ratio is low for R290 and R436a and high for R152a refrigerant.

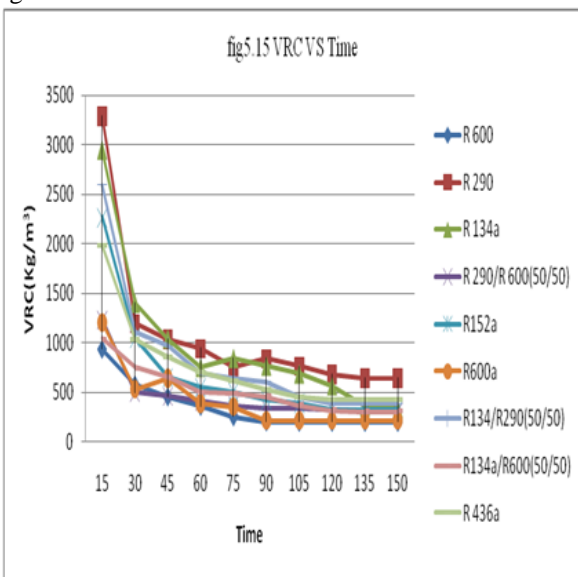

Fig 1.22 Compression ratio vs time

As shown in the fig. the volumetric cooling capacity is high for all refrigerants nt as the time pass away the volumetric cooling capacity is decrease and after some time it become constant. For R290 volumetric cooling capacity is high at the staring and after the 135 minute the volumetric cooling capacity of R290 is also high than another refrigerant I used

CONCLUSION

In this study performance analysis of the domestic refrigerator carried out by using various alternative refrigerants and blending of refrigerant in order to find the alternate of R 134a. Based on the investigation results, the following conclusion drawn:

1. Out all the refrigerants R290, R600a, R600 and R152a has the best desirable environment properties, it has zero Ozone Depletion Potential(ODP) and low global warming potential(GWP)

2. The COP of the R 152a Refrigerant is 17% is high than the R 134a and COP of R 290 is only 18% less than R 134a. During the evaporator temp. range of -25oc to -30oc R 152a has a high COP than another refrigerant while mixture of R 134a and R 600 and R 600 has low COP in compare with another refrigerant.

3. Discharge temp. of R 290 is highest in compare with another refrigerant and R 436a has slightly low discharge temp. than R290. R 134a and R 152a has same discharge temp. and R 600 and R 600 has low discharge temp. among the refrigerants.

4. Among the all refrigerants R290 has high refrigerant effect and is net refrigerant effect is 215.98KJ/Kg. And the refrigerant R 134a and R 152a has nearly same amount of refrigerant effect.

5. During the evaporator temp. rang of -200c to -300c R 152a has high compression ratio around the 20.22 while the R 134 has nearly same to the R 152a and its pressure ratio is 18.18 and Refrigerant R 600 and R 600a also compression ratio near the R 152a. While the R 290 and mixture of R 290 and R 600 has low compression ratio near the 11.11.

6. During the evaporator temp. rang of -200c to -300c the work done by the compressor is low for the R 134a around the 39.13 and the work done by the R 152a is slightly higher around the 17%.and for the R290 is 27 % higher than the R134a. And for the refrigerant R 600 and R 600a compressor work done is higher among the all refrigerant.

7. Now power consumption is low for R 152a and 18 % lower than the R 134a. power consumption for R 290 and R 436a is also high than R 134a and R 152a. Bt the refrigerant R 600a and R 600 and mixing of R134a and R 600 the power consumption is more high than the R 134a.

8. Volumetric cooling capacity For R 290 is high and is higher than R 134a is 12.2%. Volumetric cooling capacity is same for R 134a and R 152a. But Volumetric cooling capacity is much lower for the R 600 and R 600a around the 352.45Kg/m3.

9. In this study I used the mixture of R134/R600(50/50), R290/R600(50/50) and R134a/R290(50/50). But this mixture has undesirable characteristics such as a low COP, high power consumption, high compression ratio and low volumetric cooling capacity. But from these three mixtures the mixture of R134a/R290(50/50) gives better performance but these two refrigerants are not properly mixed with each other.

10. R436a refrigerant also gives some better performance such as its COP is very low than the R134a so in some cases it also can be used as an alternate of R134a.

11. But R152a and R290 refrigerants have approximately the same performance with the R134a. So R152a and R290 are good alternatives of R134a refrigerant.

REFERENCES

- [1] Performance comparison of vapour-compression refrigeration system using various alternative refrigerants A.S. Dalkilic, S. Wongwises
- [2] The study and performance of a modified conventional refrigerator to serve as a PV powered one Socrates Kaplanis, Nikolaos panastasiou
- [3] Performance of a domestic refrigerator under influence of varied expansion device capacity, refrigerant charge and ambient temperature Erik Bjork, Bjorn Palm
- [4] Theoretical analysis of a vapour compression refrigeration system with R502, R404A and R507A Akhilesh Arora, S.C. Kaushik.
- [5] A review on exergy analysis of vapour compression refrigeration system J.U. Ahamed, R. Saidur, H.H. Masjuki
- [6] Vapour Compression Refrigeration Systems, nptel IIT Kharagpur
- [7] Khorshid E., Alshiraan B., Alsairafi A., Alzemi A., Allahddad A., 2011, "Performance investigation on new refrigerant mixture" pp15-20..