

# INVESTIGATION OF MILLING OPERATION ON MILD STEEL SPECIMEN WITH DRY MACHINING AND VORTEX TUBE COOLING

Brijesh Kumar<sup>1</sup>, Adarsh Kumar<sup>2</sup>,

<sup>1</sup>M. Tech (ME) Scholar, Bansal Institute of Engineering & Technology, Lucknow

<sup>2</sup>Assistant Professor, Bansal Institute of Engineering & Technology, Lucknow

**Abstract**— The final goal of each manufacturing industry is to maximize production rate with best quality production and minimum cost. This can be achieved by optimizing the cutting speed and feed rate. We know that high temperature in cutting area reduces the quality and life of product. It also affects the various properties like strength, wear resistance, hardness and Dimensional accuracy. As we know that, water based cutting fluids are mostly used in production due to their easy availability and cooling ability, but these are messy, costly and environmentally hazardous. Water is a precious natural resource and due to lack of ground water as well other water resources, industries have to find out its alternative very soon.

The purpose of this thesis work is to analyze and study the effectiveness of the vortex tube for cooling in the milling operation. In which the compressed air is used as a coolant and it is the best choice of water. Vortex tube is a mechanical device that can separate a highly compressed air into two streams i.e. hot air and cold air. This device does not have any moving parts, and it does not use any kind of electric or chemical energy directly. It is broadly used in low temperature applications such as cooling of cutting tools, electric circuits and control cabins etc. By Using Vortex tube we can reduce the requirement of liquid coolant which is cluttered, expensive and dangerous to environment. The Aim of my work is analyze and compare surface roughness of M.S. specimen after milling process with dry cooling and after liquid cooling.

In the present work, the experimental examination of the milling operation was done to achieve a good quality surface finish without using any liquid coolant. Milling Operation M.S. Was done on. Sample The speed, cut and depth of the feed, which were accountable for surface finish, was optimized using the Taguchi method in the main parameters.

**Index Terms**— Cooling system, Vortex tube, Milling operation, Surface finish.

## I. INTRODUCTION

Cutting the metal produces heat which affects the quality of a finished product, the force required to cut and also limits the

life of the cutting device. Various efforts are made by researchers from around the world to understand the mechanisms and theories behind the temperature created during machining to achieve customized machining process and best work piece results.

High production rate with the required quality and low cost is the basic principle in the competitive manufacturing industry. This is mainly achieved using high cutting speed and feed rates. Nevertheless, under these conditions, the high temperature in the cutting area reduces the life and adversely affects the dimensional accuracy of the component and the integrity of the surface. Other properties such as strength of the device, hardness and wear resistance can also be affected. Thus, it is necessary to find the optimum cutting position (cutting speed, feed rate, machining environment, equipment material and geometry) which can produce components according to the project and can be relatively high production rate. It is known that when cutting the fluid, when properly chosen and applied, it is used to reduce the problems associated with high temperatures and high stress, because during machining, lubrication, cooling during the cutting of the tool And due to the chip flushing functions. In addition, the effectiveness of the fluid depends on the strength of the shear force with the strength of the material, by either chemical attack or physical adsorption to break the chip- tool interface and make a thin layer in the shortest possible time. Interface Cutting liquid is a type of cooling and smoothness which is specially designed for metal work and machining processes. Different types of bites are liquid, including oil, oil-water emulsion, pestis, gels, aerosols (mist), and air or other gases. They can be made from petroleum distillates, animal fats, plant oils, water and air or other raw materials. Depending on the context and which type of cutting fluid is being considered, it can be referred to as liquid cutting, oil cutting, compound cutting, cooling, or lubricant.

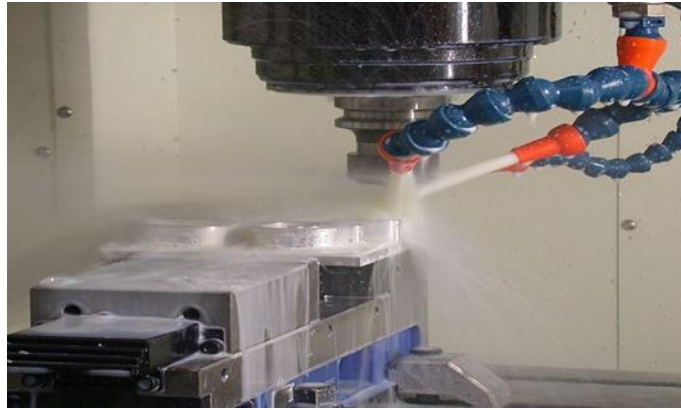

Fig. 1.1 Thin-wall milling of aluminium using water -based cutting fluid on the milling cutter

Cutting fluid is used in metal machining for many reasons, such as improving the life of the device, reducing the workpiece thermal distortion, improving the surface finish, and removing the chips from the cutting area. For this, general exception machining is cast iron and bronze, which is dry workpiece content.

The qualities which are sought after a good fluid are:

- a) The ability to keep workpieces at a constant temperature (important when working to tolerate). Very hot is acceptable, but avoids excessive hot or optional hot and cold.
- b) Maximizing the life of the tip of the cutting edge by lubricating the edges of the work and reducing tip welding.

- c) To ensure the safety of the environment for those dealing with it (toxicity, bacteria, fungi) and disposal.
- d) Rescue from war on machine parts and cutters. [2]

#### A. VORTEX TUBE COOLING SYSTEM

The vortex tube, also known as the Ranks-Hilsk vortex tube, is a mechanical device that separates a compressed gas into hot and cold streams. Fig. 1.2 shows the basic construction of a Rinke-Hilsk vortex tube, in which the air from the "hot" end can reach the temperature of 200 degrees Celsius, and the air from the "cold end" can reach up to -50 degrees Celsius. is. Do not run away from it.

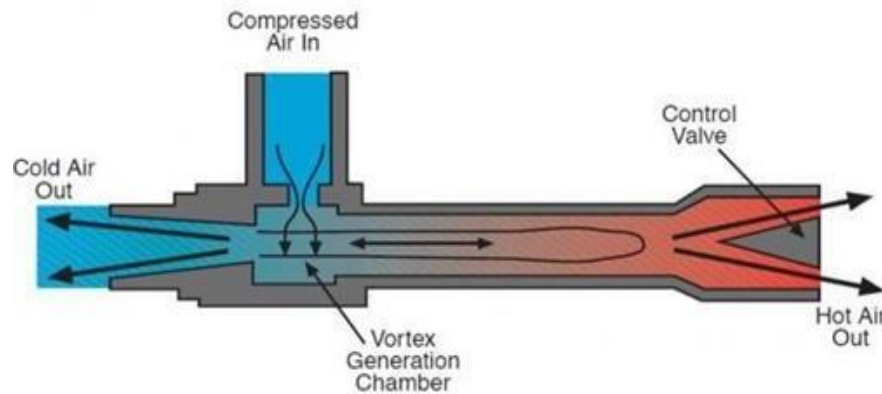

Fig 1.2 Ranque -Hilsch vortex tube

Pressurized gas is injected in a swirl chamber asymptotically and it is accelerated to rotate at a higher rate. Due to the conical nozzle at the end of the tube, only the outer cover of the compressed gas is allowed to escape at that end.

The remaining part of the gas is forced to return to an inner vortex of less diameter within the outer vortex.

Commercial vortex tube is designed to reduce the temperature of approximately

26.36 ° C (48 ° F) for industrial applications. With no moving parts, no electricity, and no Freon, a vortex tube can produce refrigeration up to 6,300 kJ using only filtered compressed air at 689 kPa. In the exhaust of hot air, a control valve adjusts temperature, flow and refrigeration on a wide range.

Vortex tubes are used during the machining to cool cutting tools (both lathes and mills, manually operated and CNC machines). Vortex tube matches this app well: machine shops usually use compressed air already, and both cool and

deplete "chips" produced by a jet engine of cold air provides both. This liquid completely eliminates or greatly reduces the need for coolant, which is dirty, expensive and dangerous to the environment. [4]

### B. MILLING OPERATION

Milling is one of the important machining works. In this operation, workpieces are fed against a rotating cylindrical device. The rotating device has many cutting edges (multiply cutting tools). Generally the axis of the rotation of the feed is given to the workpiece. Milling operation is different from other machining operations based on the orientation of the tool's axis and feed direction; However, in other operations such as drilling, turning, etc. the equipment is fed in the parallel direction of the rotation axis. The cutting tool used in the milling operation is called a milling cutter, in which there are several edges called teeth. The machine tool that makes the milling operation by creating the necessary relative speed between workpieces and tools, is called a milling machine. It provides the necessary relative speed in very controlled conditions. Generally, the milling operation creates the surface of the plane. Other geometry can also be made by milling machine. The milling operation is considered as an operation to interrupt the entry and cutting of the milling cutter during each revolution. This affects the action of biting, which converts teeth to a circle of impact force and thermal shock on every cycle. Equipment material and cutter geometry should be designed to bear the above conditions. [5]

### C. TYPES OF MILLING OPERATION

Milling operation is broadly classified as peripheral milling and face milling.

#### Peripheral Milling

This operation is also called Plane Milling Operation. In this operation, the axis of the rotating device is always kept parallel to the surface. This operation is done on the outside edges of the milling cutter. Different types of peripheral milling operations are possible as described below.

#### Slab Milling

In this milling operation, the width of the cutter extends beyond the workpiece on both sides.

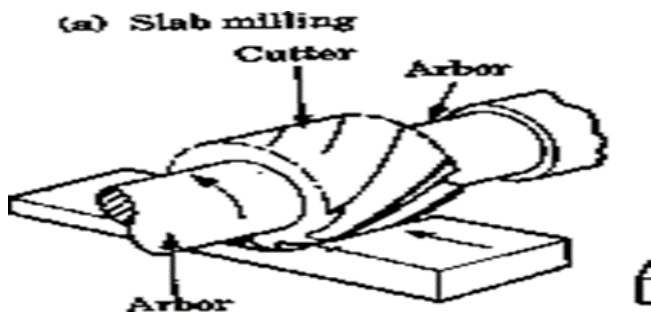

Fig. 1.3 Slab Milling

#### Slotting

It is also a type of milling operation, also called slot milling operation. In this case, the width of the cutter is less than the width of the workpiece. It is used to create slots in the workpieces. Thin slots can be made using thin milling cutters. Workpieces can be cut into two pieces by creating very thin slots in the depth of the workpiece. The workpiece is cut in such a way that slot milling is called armilling.

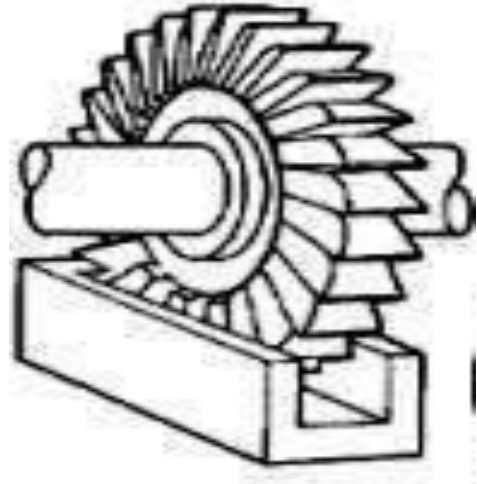

Fig. 1.4 Slotting operation

#### Side Milling

The cutter is used for milling of sides of a workpiece.

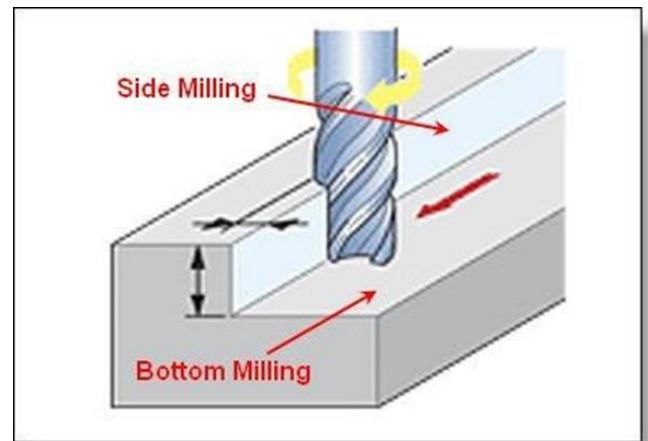

Fig. 1.5 Side milling

#### Straddle Milling

It is like the side milling with the difference that the cutting (milling operation) is simultaneously on both sides of the workpiece.

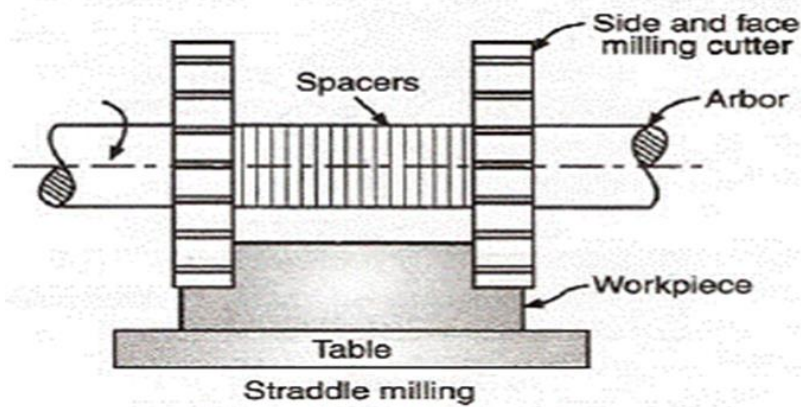

Fig. 1.6 Straddle Milling

Peripheral milling is also classified on the basis of milling and down milling, depending on rotational direction of cutter.

### Up Milling

It is also called conventional milling, in this case, cutter teeth speed is in contrast to the direction of the feed.

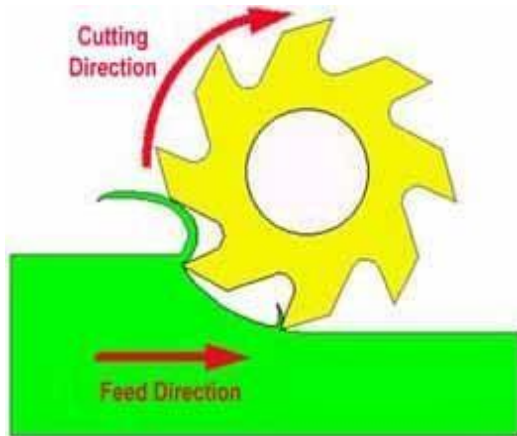

Fig. 1.7 Up milling

### Down Milling

It is also called climbing milling. In this case, the direction of cutter speed is similar to the direction of the feed speed.

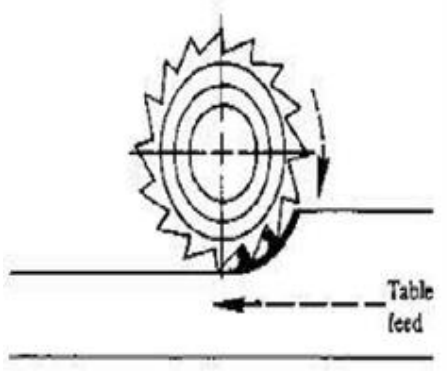

Fig. 1.8 Down milling

### Face Milling

In the operation of face milling, the spacing of the milling cutter is perpendicular to the surface. In this case, cutting the edges of both the sides of the milling cutter (the end and the outer side) are processed. Depending on geometry relative to workpieces and milling cutter face milling, different types are given below.

### End Milling

In the case of end milling, thin (low diameter) cutter is used in comparison to the width of the workpiece. It is used to create slots in the workpieces.



Fig. 1.9 End milling

### Profile Milling

It is like an end and milling in which the flat part of a flat part is on the outer side.

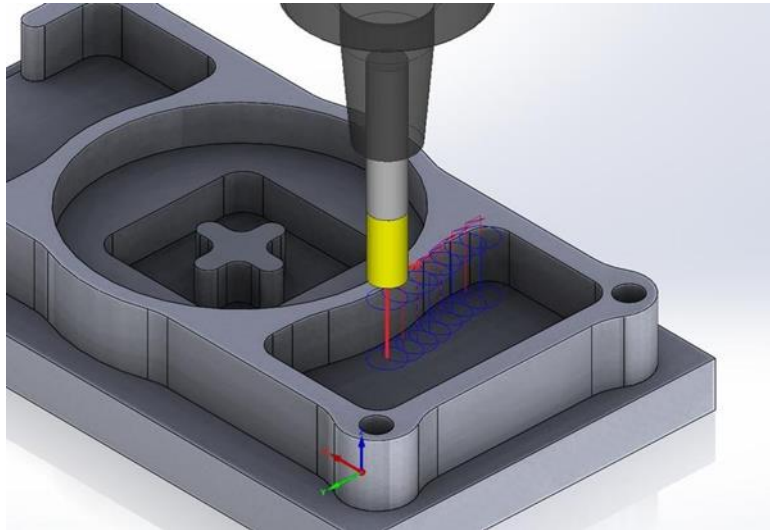

Fig. 1.10 Profile milling

### Pocket Milling

This is a selective part milling on the flat surface of the workpiece that is used to make shallow packets.



1.11 Pocket milling

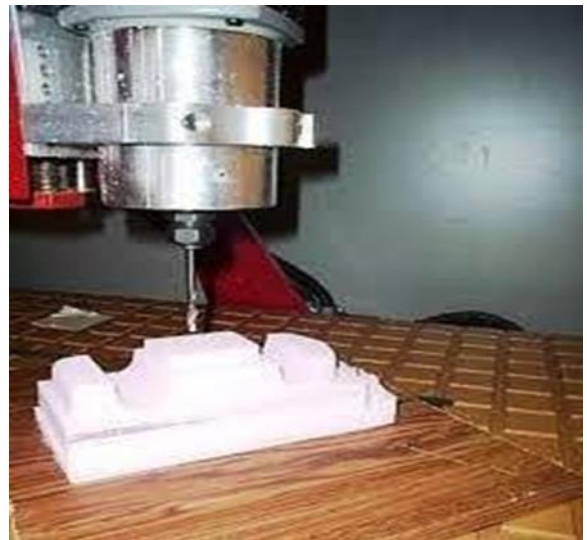

Fig. 1.12 Surface Contouring

### Surface Contouring

In this operation a ball nose cutter will work on the workpiece if the reaction and forward curve along the curvature path. This creates the necessary shape on the surface of the workpiece. This operation is used to make molds and die and this operation has been given the name of dye sinking at this time.

### D. OBJECTIVES OF THE PRESENT INVESTIGATION

The aim of present work was to study the surface finish of mild steel specimen after milling operation. Surface finish of mild steel was compared after milling operation when dry machining was done without using any coolant and when cold air from vortex tube was used as a coolant in milling operation. Step wise procedure adopted for present work is as below:

- Study of milling operation on mild steel specimen on a milling machine with horizontal arbour.
- Selection of process parameters for milling operation.
- Fabrication of vortex tube.

- Investigation of the milling operation on mild steel specimen with dry machining and with vortex tube cooling.
- Comparison of surface finish in both situations. Study of the microstructure of the test specimen in both situations.

## II. LITERATURE SURVEY

In the recent years, a lot of works has been carried on Ranque-Hilsch vortex tube and its cooling capacity under different conditions. Vortex tube is a simple device, which can separate an incoming compressed gas stream of uniform temperature into two streams one warmer than the inlet stream and the other colder than the inlet stream. This type of dissociation of gaseous fluid flux is known as the separation effect of temperature (energy) in two different streams of high and low temperatures.

Literature shows that the cooling capacity of the vortex tube can be increased by changing the design of the vortex tube. Here is the literature related to the vortex tube cooling system.

In 2003, M.H. Saidi and M.S. Valipour [10] Check the intense behavior of a vortex tube system. This work has focused on the classification of the parameters affecting the vortex tube operation. Effective parameters are divided into two different types, i.e. geometrical and thermo-physical. A reliable test rig has been constructed and tested to examine the effect of geometric parameters, that is, the length of the diameter and the main tube, the diameter of the outlet hole, the size of the entrance nozzle. Thermo-physical parameters have been specified and studied which are the inlet gas pressure, the type of gas, the cooling gas mass ratio and the moisture content of the inlet gas. The effects of these parameters on the difference and efficiency of cold temperature are discussed and presented.

In 2004, N.F. Aljuwayhel, G.F. Nellis and S.A. Klein [11] Inspect energy dissociation mechanism and flow events within a counter-flow vortex tube. A two-dimensional axial-symmetric CFD model has been developed which shows the expected general behavior from a vortex tube. Compared to model results, room temperature is done with experimental data obtained from a laboratory vortex tube operated with compressed air. The CFD model is used to check internal thermal fluid processes, which are responsible for the temperature dissociation behavior of the vortex tube. The model shows that the vortex tube flow area can be divided into three areas which correspond to: the flow which will eventually pass through the hot exhaust (hot flow area), the flow which ultimately leads to cold flow), And flow which is entered within the device (re-circuiting region). The study of underlying physical processes is done by calculating the transfer of heat and work through the control surfaces defined by the streamline separating these areas. It was found that the energy dissociation displayed by the vortex tube can be explained primarily due to a torque generated by the sticky shear acting on a rotating control surface, which separates the

cold flow zone and warm flow area. This work transfer occurs in the hot zone from the cold zone, while the net heat transfer flows in the opposite direction and hence the temperature reduces the dissociation effect. A parametric study of the effect of separating the diameter and length of the vortex tube has also been presented.

## III. METHODOLOGY

The main objective of today's manufacturing industries is to produce low cost, high quality products in less time. Choosing the optimum cutting parameters for each machining process is a very important issue in order to increase the quality of machining products and reduce machining costs. Surface inspection is done by self-inspection of mechanized surfaces. As it is a post-process operation, it becomes both time consuming and laborious. In addition, many defective parts can be found during the surface duration inspection, which leads to additional production costs. Cutting parameters (cut depth, feed rate and spindle speed) in the current work have been optimized in mild steel milling and as a result a combination of optimal levels of factors was obtained to achieve the lowest surface roughness. . Analysis analysis (ANOVA) and signal-to-noise ratio was used to study performance characteristics in the milling operation. Analysis also shows that the estimated value and calculation values are very close, which clearly indicates that the developed model can be used to estimate surface roughness in the operation of light steel.

In the proposed work, the effect of the cooling effect produced by the vortex tube on surface finish is checked using conical valve displacement mechanism in the vortex tube. In order to achieve the above mentioned objectives, the following methodology was to be employed during the present work:

- Different studies of different types of milling operations.
- The type of coolant used in the milling operation and coolant type used in milling operation.
- Ranque-Hilsch studying the vortex tube and its design facilities.
- Studying the cooling capacity of the vortex tube and its use as a cooling system for milling operation.
- Selecting a suitable vortex tube for operation.
- Optimization of milling process parameters.
- Methods of experiments using the Method taguchi method.
- Mintab 17 software is used to analyze Ab usage.
- Validation of results by confirmation test.
- Milling operation was done on light steel samples on the milling machine with horizontal arbour.

### A. DESIGN FEATURES OF VORTEX TUBE

The Ranque–Hilsch vortex tube is a simple device in which a stream of high pressure gas swirls to split into two low pressure streams, one higher than at entry temperature and the other lower. The drop in pressure more than accounts for this apparent breach of the Second Law of Thermodynamics, which nevertheless puts a limit on performance. On the

pressure drop ratio of 5 and the ambient temperature, the temperature difference of 30 K (or 10% of the environment) is easily obtained, enough for ordinary refrigeration. The lack of moving parts, electricity etc., make the device attractive for a number of specialized applications where simplicity, robustness, reliability and general safety are desired, either as a supply of hot or, more likely, cold gas.



Fig 3.1 Fabrication of vortex tube

### B. SELECTION OF SUITABLE VORTEX TUBE AND TEMPERATURE MEASUREMENT

Vortex tube is fabricated using PVC pipes and mounted on wooden sheet as shown in fig. 3.2. Hot end of vortex tube

is almost closed with wooden conical valve and cold end is open initially which further closed with a reducing valve for the purpose of temperature measurement.

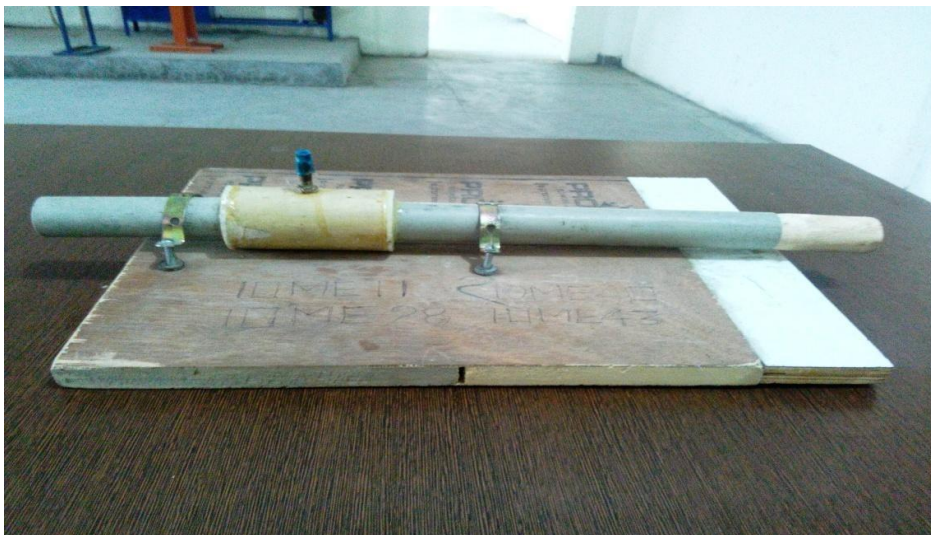

Fig. 3.2 Vortex tube

Temperature measurement set up of vortex tube is shown in fig. 3.3, compressed air enters at inlet of vortex tube through nozzle at a temperature and pressure of 30.2 °C and 40 psi. Inside the vortex tube rotating air move

towards the hot end where it is restricted by conical valve, then it flow backward towards the orifice and cold end. While moving backward it exchange heat with air coming toward hot end at a higher speed and thus temperature of

the air moving toward cold end decreases and temperature of the air which exit at hot end increases. In this set up we recorded the temperature of cold end air as 21.9 °C and temperature of the hot end air as 34.5 °C.

**C. SELECTION OF SIGNIFICANT PROCESS PARAMETERS OF MILLING USING VORTEX TUBE**

The significant milling parameters which are primarily responsible for the surface finish are selected by studying the

milling process and previous research papers. The non-significant process parameters are dropped and the significant parameters are selected for the further analysis and optimization. The three most significant process parameters, cutting speed, depth of cut and feed are selected and tried by different combination of process parameter levels. The Table 3.1 described the various milling process parameters.



Fig. 3.3 Temperature measurement of Vortex tube

TABLE 3.1: SELECTION OF MILLING PROCESS PARAMETERS

Process Parameter	Significance (↓-Significant, X-Insignificant)	Remarks
Cutting speed	↓	High cutting speed gives better surface Finish
Depth of cut	↓	Less depth of cut gives better surface finish
Feed	↓	Low feed gives better surface finish
Workpiece material	X	Material used is Mild steel
Tool material	X	Tool material is same for all the runs
Ambient conditions	X	Ambient conditions were same for all the runs
Type of coolant	X	It is cold air from vortex tube
Amount of coolant	X	It is fixed for all the runs



#### IV. EXPERIMENTAL VALIDATION

Milling is a widely used manufacturing process in the industry. After deep study of all the factors it was observed that the major factors responsible for surface roughness of the product were cutting speed, depth of cut, feed and type of coolant, amount of coolant used. The process parameters of milling using vortex tube as a cooling system were optimized to get a least value of average surface roughness. Taguchi Method was to be adopted for this specific purpose which had capabilities to design a set of experiments according to process parameters and their stages under the fixed tolerance limits.

##### A. EXPERIMENTAL SETUP

Surface Roughness Measurement There are various methods available for measuring the surface roughness of the

work piece. The arithmetic surface roughness value ( $R_a$ ) was adopted and the measurement was done using a surfast SJ-210 in the center of the left and right side and the surface. Before conducting the measurement, all the samples were cleaned with acetone. The  $R_a$  values of the surface were obtained by averaging the surface roughness.

##### Surface Roughness Tester

**Brand: (Mitutoyo) SURFTEST, Model: SJ-210**

The surface roughness of machine work pieces was measured using this machine. SURFTEST SJ-210 is a shop-floor type surface roughness measuring device that detects surfaces of various machine parts, calculates the roughness of their surface based on roughness standards and displays the results.



Fig. 4.1 SURFTEST SJ-210



Fig. 4.2 Measurement of surface roughness

##### B. OPTIMIZATION OF PROCESS PARAMETERS

The determination of which factors to investigate depends on the responses of interest. The significant milling parameters which are primarily responsible for the surface finish are selected by studying the milling process and previous research papers. The non-significant process parameters are dropped and the significant parameters are selected for the further analysis and optimization. The three most-significant process

parameters, cutting speed, depth of cut and feed are selected and tried by different combination of process parameter levels. The three most significant process parameters are:

- Cutting speed.
- Depth of cut.
- Feed

The combination of these process parameters were tried for different levels within the permissible range according to workpiece material characteristics and machinability. In this

regard, brain-storming was done with the lab operators of institute and industry personnel. The range for cutting speed was selected between 400 to 700 RPM. The depth cut was taken between 1 to 2.5 mm and feed rate was selected between 0.5 to 2 mm/rev. Table-4.1 displays the levels of various process parameters.

TABLE 4.1: PROCESS PARAMETERS FOR MILLING OF MILD STEEL

Response Variable – Average surface roughness value

Process Parameters	Level 1	Level 2	Level 3	Level 4
Cutting speed (RPM)	400	500	600	700
Depth of cut (mm)	1	1.5	2	2.5
Feed (mm/rev)	0.5	1	1.5	2

operation is performed on mild steel specimens of dimensions 48 x 46 x 5 mm, shown in fig. 4.3.



Fig. 4.3 Mild steel specimen without

### C. COMPARISON OF SURFACE FINISH ON MILD STEEL SPECIMENS

Main objective of this work was to utilize vortex tube as a cooling system and to use cold air from the cold end of the vortex tube as coolant in milling operation. Milling

#### 1) USING NO COOLANTS

Mild steel specimens of dimension 48 x 46 x 5 mm were machined on a milling machine with a horizontal arbor, 25 mm diameter and no cutting fluids were used. Surface roughness was measured using SurfTest SJ-210.



Fig. 4.4 Milling of mild steel specimen without coolant

#### 2) USING VORTEX TUBE COOLING SYSTEM

Mild steel specimens of dimension 48 x 46 x 5 mm were machined on a milling machine with a horizontal arbor of 25 mm diameter and cold air from vortex tube was used as

a coolant. A HSS milling cutter of 25.4 mm diameter and having 24 teeth is used in the operation. Surface roughness was measured using SurfTest SJ-210.



Fig. 4.5 Milling of mild steel specimen with vortex tube cooling

## V. RESULTS AND DISCUSSION

The Taguchi method is used to optimize the results obtained from each test. In the current work, the L16 orthogonal array is used for testing purposes. The reaction of the S / N ratio, the contribution of various process parameters and the relationship between the S / N ratio and the level of different process parameters are studied and

### A. ANALYSIS RESPONSE OF S/N RATIO

The average value of S/N ratio for each level for each factor is shown in Table 5.1. The table contains ranks based on delta data, which compares the relative magnitude of the effects. Delta data is the lowest average for each factor from

analyzed so that the optimum process parameters can be achieved. There are three categories of quality specifications in the analysis of S / N ratio, i.e. small-to- better, large-to-better, nominal-best As the main objective of the study was to reduce the average surface roughness value, for which the ideal value is zero, the quality characteristics of the S / N ratio for each level of the process parameters have been calculated using small- better.

the highest zero. Mintab delta provides a rank based on prices; Highest delta value from rank 1, rank 2 to second highest, and so on. The rank indicates the relative importance of each factor for the reaction. Ranks and delta values indicate that the cutting speed is maximum and the depth of the cut has minimal impact on the roughness value.

TABLE 5.1:RESPONSE TABLE FOR SIGNAL TO NOISE RATIOS  
[Smaller is better  $[-10 \cdot \log_{10} (\sum(Y^{**2})/n)$ ]

Process Parameters	Level-1	Level-2	Level-3	Level-4	□	Rank
					(Max–Min)	
Cutting speed	-22.4892	-5.9374	-16.3770	0.0218	22.5111	1
Feed	-11.9250	-5.6528	-14.6376	-12.5664	8.9848	2
Depth of cut	-11.8670	-8.9024	-11.0833	-12.9291	4.0267	3

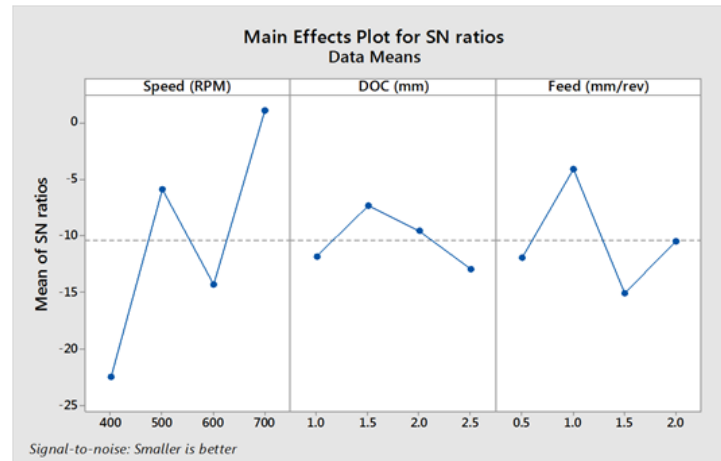

Fig 5.1: Main Effects Plot for S/N Ratios

From the Main effect plot shown above it can be concluded that for cutting speed the optimum value is 700 RPM as the S/N ratio is maximum at this speed. The optimum value of depth of cut for which S/N ratio has maximum value is 1.5 mm. For the parameter feed the optimum value is 1 mm.

## VI. CONCLUSIONS

In the present work experimental investigations of milling operation were carried out to obtain a good quality surface finish without using any conventional coolant. Milling operation was performed on mild steel specimen. The major parameters Cutting speed, Depth of cut and Feed, which were responsible for surface finish were optimized using the Taguchi method. The following conclusions are drawn from the present investigation:

It is concluded that Cutting speed and Feed are major factors that significantly affect the surface roughness of the mild steel. The other factor, Depth of cut is found to be insignificant. It is concluded that optimum value of for cutting speed is found to be 700 RPM and for feed it is 1mm/rev.

- The surface roughness value was obtained using optimum process parameter is 1.03 micron.
- Surface roughness value is reduced by using vortex tube cooling system as compared to dry machining.

## REFERENCES

[1] G.J. Ranque. Method and apparatus for obtaining from a fluid under pressure two currents of fluid at different temperatures. United States Patent 1952281, March 27, 1936.

[2] G.J. Ranque. Experiment on expansion in a vortex tube with simultaneous expansion of hot air and cold air. *Le Journal de Physique et Le Radium* (Paris), 1933, v.4.1128.

[3] R. Hilsch. The use of the expansion of gases in a centrifugal field as a cooling process [J]. *The review of scientific instruments*, 1947, 8(2): 108-113.

[4] Zhang W.Z. The application of vortex tube in industrial field.

[5] Hu H.T. Air refrigeration cycle characteristics and a new type of refrigeration equipment research. *Energy Saving*. 2001(12):13-15.

[6] Sun. G.H. Refrigeration theory and application of vortex tube. 1988

[7] Cao Y. Development and summary of vortex tube research[J]. *Cooling Engineering*. 2001(6):1-5.

[8] Huang F.G. Application and practice of vortex tube refrigeration. 1992(3):49-53.

[9] Ding Y.G. Application of vortex tube. *Cooling Engineering*. 2004(1)

[10] Sha Q.Y. New skill of gas handling. 1994.

[11] Fulton C D. Ranque's tube. *ASRE Refrigeration Engineering*, 1950, 58(5): 473- 479.

[12] Van Deemter J S. On the theory of the Ranque-Hilsch cool effect. *Applied scientific Research (Series A)*, 1952,3(3): 174-196