

DETECTION OF FAULT ON POWER TRANSMISSION LINE USING ARTIFICIAL NEURAL NETWORK

¹Priyanka, ²Mr. Mon Prakash Upadhyay, ³Mr. Rajat varshney

¹Student, M.Tech. Department of Electronics & Communication,
Invertis University, Bareilly, India

¹reachpriya101@gmail.com, ²mon.u@invertis.org, ³rajat.v@invertis.org

Abstract— Due to various random causes there may be some unexpected failure on power transmission line. The main objective of artificial neural network is to solve specific problem especially by learning and training approach. It is considered to be very similar to human brain. This paper gives overview of the fault that has occurred on the power transmission line and their detection using artificial neural network. An ANN resembles biological system which involves the interconnection and adjustment to the synaptic junctions that exists between neurons. As artificial neural network is a computational approach, data modeling becomes very easy as compared to the traditional approaches.

Keyword — Transmission line, faults, protection, neural network.

I. INTRODUCTION

Fault detection in electrical power transmission system using artificial neural network:

The fault detection of an electrical Transmission Lines can be achieved by following steps:

1. Development of simulink Model of the Transmission Lines
2. Measurement of network parameters (Sampled Data) for fault detection & analysis
3. Training & Testing of Artificial Neural Networks
4. Fault Detection

A. Development of simulink Model of the Transmission Lines:

The Model used in Power Transmission systems are as:

1. Two 3-Phase AC Source : Generators of 400kV/50Hz is used
2. Source Impedance of Generators
3. Transmission Lines (300 km long)
4. Load
5. Measurement Blocks for measuring Voltage, Current
6. Fault Blocks (60 Km)
7. Data link blocks from SIMULINK to Workspaces

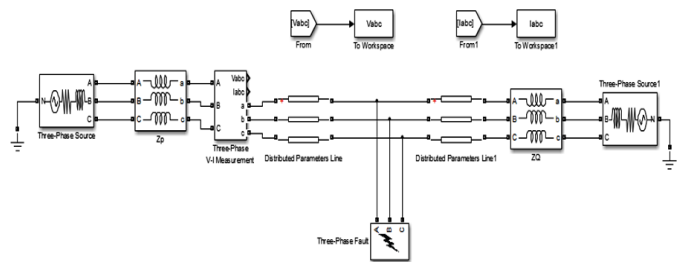

B. Measurement of network parameters (Sampled Data) for fault detection & analysis:

1. Current & Voltage is measured in Fault free conditions
2. Current & Voltage is measured ANS samples @ 1000Hz frequency
3. The inputs used to the neural network are the ratios of the voltages and currents in each of the phases before and after the occurrence of fault. The advantage of performing this scaling is to reduce the training computation time

C. Training & Testing of Neural Networks:

The Neural Network toolbox in Simulink of MATLAB uses the entire data set in three parts:

1. Training Datasets: Computing the gradient and updating the network weights until the network converges for given value of errors

For the task of training the neural networks for different stages, sequential feeding of input and output pair has been adopted. In order to obtain a large training set for efficient performance, each of the ten kinds of faults has been simulated at different locations along the considered transmission line.

In view of all these issues, about 100 different fault cases for each of the 10 kinds of faults have been simulated. Apart from the type of fault, the phases that are faulted and the distance of the fault along the transmission line, the fault resistance also has been varied to include several possible real-time fault scenarios.

The fault resistance has been varied as follows: 0.25, 0.5, 0.75, 1, 5, 10, 25, 50 Ω . Also, the fault distance has been varied at an incremental factor of every 3 km on a 300 km transmission line

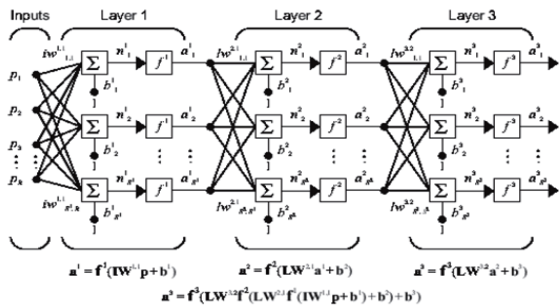

The network shown above has R^1 inputs, S^2 neurons in the first layer, S^3 neurons in the second layer, etc. It is common for different layers to have different numbers of neurons. A constant input 1 is fed to the bias for each neuron.

- Validation Datasets: The error in validation process for entire validating set is monitored throughout the training process. When the neural network during validation begin the over fitting the given data, the validation errors increase and when the number of validation process fails and increase beyond a particular value, the training process ends to avoid further over fitting the data and the neural network is returned to the minimum number of validation error.
- Testing Datasets: used to judge the overall performance of the finally developed trained neural network. If the test data set reaches up to the minimum value of mean square error at any significantly different iteration than the validation set, it means that the neural network will not be able to provide satisfactory performance and needs to be re-architecture.

D. Fault Detection:

- The neural network is provided with six inputs during the fault detection process. The inputs are three voltages of respective three phases and three currents of the respective three phases. The value of input voltages and input currents are normalized with respect to the pre-fault values of the voltages and currents respectively
- All ten different types of faults and no fault condition have been considered in developing the data set. The training set consist of total 8,712 input and 8,712 output samples (792 for each of the ten faults and 792 for the no fault case), which basically forms a set of six inputs and one output in each input–output pattern.
- The output of the neural network is in simple yes or no form, i.e. 1 or 0, which indicates whether the fault has been occurred or not
- Validation of ANN:
 - Plot the confusion matrices for the various types of errors that occurred for the trained neural network
 - The diagonal cells in green indicate the number of cases that have been classified correctly by the neural network and the off-diagonal cells which are in red indicate the number of cases that have been wrongly classified by the ANN.
 - The last cell in blue in each of the matrices indicates the total percentage of cases that have been classified correctly in green and the vice versa in red. It can be seen that the chosen neural network has 100 percent accuracy in fault detection.

Output Class	1	59 33.1%	0 0.0%	0 0.0%	100% 0.0%
	2	0 0.0%	71 39.9%	0 0.0%	100% 0.0%
	3	0 0.0%	0 0.0%	48 27.0%	100% 0.0%
		100% 0.0%	100% 0.0%	100% 0.0%	100% 0.0%
		1	2	3	
		Target Class			

CONCLUSION

In this paper we have studied the application of artificial neural networks for the detection and classification of faults on a three phase transmission lines system. The method developed utilizes the three phase voltages and three phase currents as inputs to the neural networks.

Type of fault	Phase A	Phase B	Phase C	Ground
AG	1	0	0	1
BG	0	1	0	1
CG	0	0	1	1
AB	1	1	0	0
BC	0	1	1	0
CA	1	0	1	0
ABG	1	1	0	1
BCG	0	1	1	1
CAG	1	0	1	1
ABC	1	1	1	0

The inputs were normalized with respect to their pre-fault values respectively. The results shown in the paper is for line to ground fault only. The other types of faults, e.g. line-to-line, double line-to-ground and symmetrical three phase faults can be studied and ANNs can be developed for each of these faults.

All the artificial neural networks studied here adopted the back-propagation neural network architecture. The simulation results obtained prove that the satisfactory performance has been achieved by all of the proposed neural networks and are practically implementable. The importance of choosing the most appropriate ANN configuration, in order to get the best performance from the network, has been stressed upon in this work. The sampling frequency adopted for sampling the voltage and current waveforms in this research work is 1,000 Hz.

Some important conclusions that can be drawn from the research are:

Artificial neural networks are a reliable and effective method for an electrical power system transmission line fault classification and detection especially in view of the increasing dynamic connectivity of the modern electrical power transmission systems.

The performance of an artificial neural network should be analyzed properly and particular neural network structure and learning algorithm before choosing it for a practical application.

Back propagation neural networks delivers good performance, when they are trained with large training data set, which is easily available in power systems and hence back propagation networks have been chosen for proposed method.

The scope of ANN is wide enough and can be explored more. The fault detection and classification can be made intelligent by nature by developing suitable intelligent techniques. This can be achieved if we have the computers which can handle large amount of data and take least amount time for calculations.

REFERENCES

- [1] Rubio JJ, Ortiz F, Mariaca CR, Tovar JC (2013) A method for online pattern recognition for abnormal eye movements. *Neural Comput Appl* 22(3-4):597-605View ArticleGoogle Scholar.
- [2] Sanaye-Pasand M, Kharashadi-Zadeh H (2006) An extended ANN-based high speed accurate distance protection algorithm. *Electr Power Energy Syst* 28(6):387-395View ArticleGoogle Scholar.
- [3] Venkatesan R, Balamurugan B (2007) A real-time hardware fault detector using an artificial neural network for distance protection. *IEEE Trans Power Deliv* 16(1):75-82View ArticleGoogle Scholar.
- [4] Ye J (2014) Compound control of a compound cosine function neural network and PD for manipulators. *Int J Control* 87(10):2118-2129Google Scholar.