

DESIGN AND IMPLEMENTATION OF OFDM SYSTEM AND REDUCTION OF INTER-CARRIER INTERFERENCE

Gaurav Verma¹, Navneet Singh²

¹Research Scholar, JCDMCOE, Sirsa

²Assistance Professor, JCDMCOE, Sirsa
gaurav.vermamec@gmail.com

Abstract- Orthogonal frequency-division multiplexing (OFDM) [1] is a method of encoding digital data on multiple carrier frequencies. OFDM[1] has developed into a popular scheme for wideband digital communication, whether wireless or over copper wires, used in applications such as digital television and audio broadcasting, DSL Internet access, wireless networks, powerline networks, and 4G mobile communications. In the Several wireless standards such as IEEE 802.11a[2] and HiperLAN2[3].The orthogonality of the subcarriers is no longer maintained which results in ICI (Inter carrier Interference)[4].ICI reduction techniques achieve a better SNR and BER in OFDM at zero phase noise variance . This technique will use a large number of closely spaced orthogonal subcarriers to avoid phase noise. It provides high data rates with sufficient robustness to radio channel damages. A major problem in OFDM is carrier frequency offset error between the transmitted and received signals. Due to this the orthogonality of the subcarriers is no longer maintained which results in ICI (Inter carrier Interference). In this paper, we used the ICI self-cancellation technique and reduced the ICI and improved the BER and SNR we are also calculate the SNR=15db and 20db at different phase noise variance.

Index Terms- Inerter Carrier Interference, multicarrier frequency, self-cancellation, Phase noise.

I. INTRODUCTION

OFDM[1] is a frequency-division multiplexing (FDM) scheme used as a digital multi-carrier modulation method. A large number of closely spaced orthogonal sub-carrier signals are used to carry data on several parallel data streams or channels. Each sub-carrier is modulated with a conventional modulation scheme (such as quadrature amplitude modulation or phase-shift keying) at a low symbol rate, maintaining total data rates similar to conventional single-carrier modulation schemes in the same bandwidth.

The primary advantage of OFDM over single-carrier schemes is its ability to cope with severe channel conditions (for example,attenuation of high frequencies in a long copper wire, narrowband interference and frequency-selective fading due to multipath) without complex equalization filters. Channel equalization is simplified because OFDM may be viewed as using many slowly modulated narrow band signals rather than one rapidly modulated wideband signal. The low symbol rate makes the use of a guard interval between symbols affordable, making it possible to eliminate inter symbol interference (ISI) and utilize echoes and time-spreading (on analogue TV these are visible as ghosting and blurring, respectively) to achieve a diversity gain, i.e. a signal-to-noise ratio improvement. This mechanism also facilitates

the design of single frequency networks (SFNs), where several adjacent transmitters send the same signal simultaneously at the same frequency, as the signals from multiple distant transmitters may be combined constructively, rather than interfering as would typically occur in a traditional single-carrier system.OFDM is a special form of multicarrier modulation technique which is used to generate waveforms that are mutually orthogonal and then distributes the data over a large number of carriers that are spaced apart at precise frequencies. This spacing provides the "orthogonality" in this technique which prevents the demodulators from seeing frequencies other than their own. In an OFDM scheme, a large number of orthogonal, overlapping, narrow band subcarriers are transmitted in parallel. These carriers divide thea vailable transmission bandwidth. The separation of the subcarriers is such that there is a very compact spectral utilization. With OFDM, it is possible to have overlapping sub channels in the frequency domain (Figure 1), thus increasing the transmission rate.

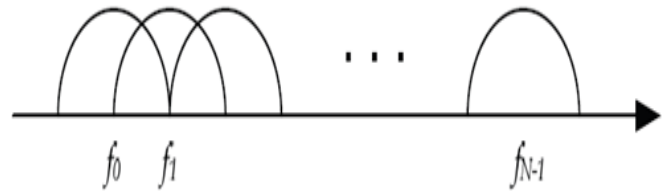

Fig.1:- power spectrum of the transmitted signal

In order to avoid a large number of modulators and filters at the transmitter and complementary filters and demodulators at the receiver, it is desirable to be able to use modern digital signal processing techniques, such as fast Fourier transform (FFT). OFDM is a promising candidate for achieving high data rates in mobile environment because of its multicarrier modulation technique and ability to convert a frequency selective fading channel into several nearly flat fading channels. This technology has been chosen as the transmission method of many standards, such as Digital Subscriber Line (DSL), European Digital Audio and Video Broadcasting terrestrial (DAB/DVB-T), European HIPERLAN/2 and IEEE 802.11 a/g for wireless local area networks (WLAN), Worldwide Interoperability for Microwave Access (WiMAX), etc. However, OFDM systems exhibit a sensitivity to phase noise higher than single carrier modulations due to its long symbol period. Because carriers are kept very close to each

other, OFDM is very sensitive to distortion that may remove the orthogonality between carriers.

Phase noise can cause several types of signal degradation that are usually very difficult to quantify analytically. When the modulation experiences phase noise, it encounters two problems:

- a) A common phase rotation over all the carrier frequencies which rotate the entire signal space for a given OFDM symbol
- b) Inter-carrier interference due to the loss of orthogonality between subcarriers.

Especially, the ICI seriously degrades system predominance because it may break down the orthogonality between subcarriers.

II. ORTHOGONAL FREQUENCY DIVISION MULTIPLEXING

Orthogonal Frequency Division Multiplexing [5] is a technology related to Frequency Division Multiplexing. With it, many different signals can be sent over the same medium, at the same time. Each signal uses a different basis function. By using the basis function given, the sender and recipient will then see their signal better, the other signals will be clearly separated.

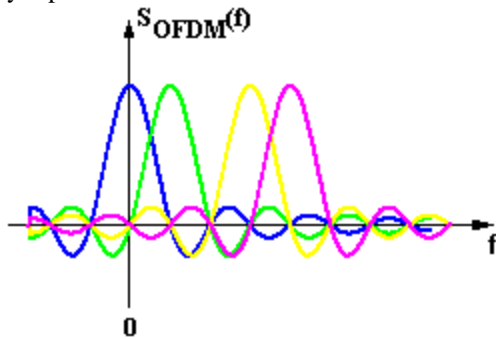

Fig.2:-An example of OFDM with 4 different signal shown in different colour

I. Orthogonality

If two signals are said to be orthogonal then their dot product is zero. As the subcarriers are orthogonal then the spectrum of each subcarrier has a null at the center frequency of the other subcarriers in the system. It is as shown in the figure.2

II. OFDM Generation And Reception

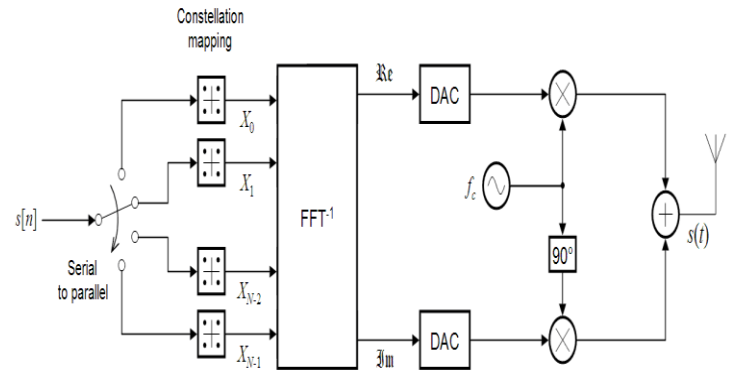

Fig 3 TRANSMITTER

An OFDM carrier signal is the sum of a number of orthogonal sub-carriers, with baseband data on each sub-carrier being independently modulated commonly using some type of quadrature amplitude modulation (QAM) or phase-shift keying (PSK). This composite baseband signal is typically used to modulate a main RF carrier. $s[n]$ is a serial stream of binary digits. By inverse multiplexing, these are first demultiplexed into N parallel streams, and each one mapped to a (possibly complex) symbol stream using some modulation constellation (QAM, PSK, etc.). Note that the constellations may be different, so some streams may carry a higher bit-rate than others.

An inverse FFT is computed on each set of symbols, giving a set of complex time-domain samples. These samples are then quadrature-mixed to passband in the standard way. The real and imaginary components are first converted to the analogue domain using digital-to-analogue converters (DACs); the analogue signals are then used to modulate cosine and sine waves at the carrier frequency, f_c , respectively. These signals are then summed to give the transmission signal, $s(t)$.

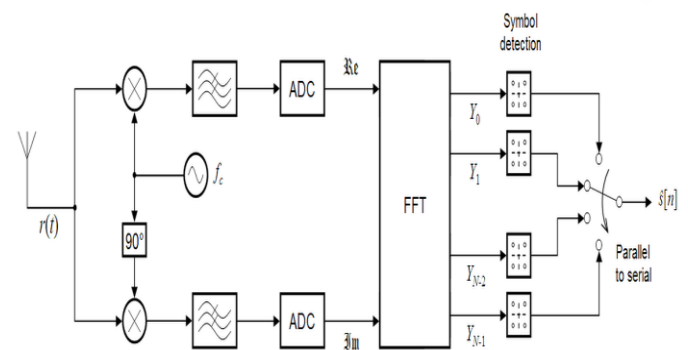

Fig: 4 RECIVER

The receiver picks up the signal $r(t)$, which is then quadrature-mixed down to baseband using cosine and sine waves at the carrier frequency. This also creates signals centered on $2f_c$, so low-pass filters are used to reject these. The baseband signals are then sampled and digitised using analog-to-digital converters (ADCs), and a forward FFT is used to convert back to the frequency domain.

This returns N parallel streams, each of which is converted to a binary stream using an appropriate symbol detector. These streams are then re-combined into a serial stream, $\hat{s}[n]$, which is an estimate of the original binary stream at the transmitter.

III. ICI SELF CANCELLATION METHODS

It is seen that the difference between the ICI co-efficient of the two consecutive sub-carriers is very small. This makes the basis of ICI self cancellation. Here one data symbol is not modulated in to one sub-carrier, rather at least in to two consecutive sub-carriers. If the data symbol =a' is modulated in to the 1st sub-carrier then =-a' is modulated in to the 2nd sub-carrier. Hence the ICI generated between the two sub-carriers almost mutually cancels each other. This method is suitable for multipath fading channels as here no channel estimation is required.

IV. CONCLUSION

In this paper we have calculated the BER and SNR at different phase noise variance from zero to 10 and we have seen that when the phase noise variance is increased BER and SNR performance is decreased as well as we calculated the BER at SNR=15 db and 20 db. The improved graph as bellow.

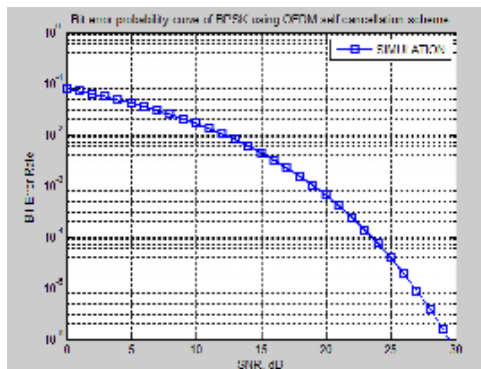

Fig 5:- Best BER performance with ICI cancellation at zero phase noise variance

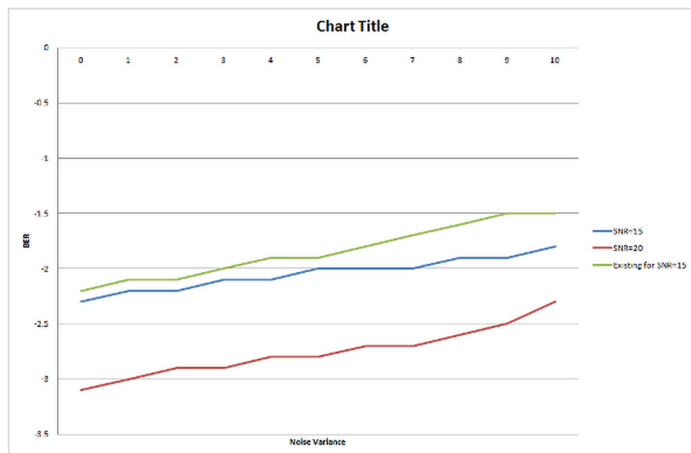

Fig 6: BER at different phase noise variance at SNR=15db and 20db

REFERENCES

[1] M.M. Islam, D. Zhang, G. Lu. A geometric method to compute directionality features for texture images. *In proceeding of:*

Proceedings of the 2008 IEEE International Conference on Multimedia and Expo (ICME), 2008.

[2] http://en.wikipedia.org/wiki/Orthogonal_frequency_division_multiplexing

[3] http://en.wikipedia.org/wiki/IEEE_802.11

[4] <http://en.wikipedia.org/wiki/HiperLAN>

[5] [http://en.wikipedia.org/wiki/Interference_\(communication\)](http://en.wikipedia.org/wiki/Interference_(communication))

[6] http://simple.wikipedia.org/wiki/Orthogonal_frequency_division_multiplexin

[7] <http://link.springer.com/article/10.1007%2Fs00034-012-9477-z#page-1>

[8] <http://link.springer.com/article/10.1007/s11277-012-0846-5#page-1>

[9] <http://ieeexplore.ieee.org/xpl/login.jsp?tp=&arnumber=6511240&url=http%3A%2F%2Fieeexplore.ieee.org%2Fiel7%2F6506960%2F6511176%2F06511240.pdf%3Farnumber%3D6511240>

[10] http://ieeexplore.ieee.org/xpl/login.jsp?tp=&arnumber=6471546&url=http%3A%2F%2Fieeexplore.ieee.org%2Fxppls%2Fabs_all.jsp%3Farnumber%3D6471546

[11] <http://ieeexplore.ieee.org/xpl/login.jsp?tp=&arnumber=6133563&url=http%3A%2F%2Fieeexplore.ieee.org%2Fiel5%2F6132211%2F6133457%2F06133563.pdf%3Farnumber%3D6133563>

[12] http://ieeexplore.ieee.org/xpl/login.jsp?tp=&arnumber=5418836&url=http%3A%2F%2Fieeexplore.ieee.org%2Fxppls%2Fabs_all.jsp%3Farnumber%3D5418836

[13] http://ieeexplore.ieee.org/xpl/login.jsp?tp=&arnumber=4291833&url=http%3A%2F%2Fieeexplore.ieee.org%2Fxppls%2Fabs_all.jsp%3Farnumber%3D4291833

[14] <http://ijarcsee.org/index.php/IJARCSEE/article/view/408>

[15] <http://ieeexplore.ieee.org/xpl/articleDetails.jsp?arnumber=6550889>

[16] <http://ieeexplore.ieee.org/xpl/login.jsp?tp=&arnumber=5752209&url=http%3A%2F%2Fieeexplore.ieee.org%2Fiel5%2F11%2F5993771%2F05752209.pdf%3Farnumber%3D5752209>

[17] <http://www.mathworks.in/products/matlab/>