

# DESIGN DEVELOPMENT OF LOW COST SEED DRILL

Shahzad Ahmed<sup>1</sup>, Prof. S. M. Choudhary<sup>2</sup>  
Mechanical Engineering Department  
Wainganga College of Engineering & Management  
Nagpur, India

<sup>1</sup>[shehzad.engg@gmail.com](mailto:shehzad.engg@gmail.com)  
<sup>2</sup>[smchoudhary001@gmail.com](mailto:smchoudhary001@gmail.com)

**Abstract**— Indian economy is agrarian economy. Around 70% population of our country is depending on agriculture for their livelihood. Agriculture will continue to be the main driver of country's economic growth in particular and globe in general. In spite of the above fact, not much has been done in the field of farming. On the other hand, the farmers are facing many problems and day by day suicidal cases are increasing all around the country. Following are the some serious problems faced by majority Indian farmers. To name a few:

- Poverty
- Illiteracy
- Low income
- Poor health
- Low productivity
- Adverse conditions of work

In view of above fact, it is the need to contribute in the field of farming since farmers and many other villagers toiling their efforts in the farms and getting bare minimum returns for their work. Moreover, the sowing activity of farming is labor intensive, costly and becoming unaffordable in present condition. This demands the design farming equipment to solve seed sowing machine, which will be economical, affordable, multitasking and user friendly.

This machine is named as "SEEDS SOWING CART". Purni is a common word, used in Marathi, in Maharashtra for sowing activity in farm. This machine is particularly used for sowing seeds of wheat, soya bean in farm, but it can also be modified, to sow any other seed too, since arrangement of with control between seeds, length control and depth control is provided with simultaneous spreading of fertilizer at proper distance and depth from seeds and ground level respectively. In addition, this machine is designed considering most suitable parts and optimum design parameters. In future this machine will prove to be a boon for farmers of our country.

**Index Terms**— Agriculture, Low productivity, Design, Multitasking, (key words)

## I. INTRODUCTION

Agriculture has been the backbone of the Indian economy and it will continue to remain so for a long time. It has to support almost 17 percent of world population from 2.3 percent of world geographical area and 4.2 percent of world's water resources. The present cropping intensity of 137 percent has registered an increase of only 26 percent since 1950-51. The net sown area is 142 Mha.

In the farming process, often used conventional seeding operation takes more time and more labor. The seed feed rate is more but the time required for the total operation is more and the total cost is increased due to labor, hiring of equipment. A conventional seed sowing machine is less efficient, time consuming.

This project deals with the design and fabrication of multipurpose seed sowing machine as the basic objective of sowing operation is to put seed and fertilizer in rows at desired depth and spacing, cover the seeds with soil and provide proper compaction over the seed. The recommended row to row spacing, seed rate, seed to seed spacing and depth of seed placement vary from crop to crop and for different agro-climatic conditions to achieve optimum yields and an efficient sowing machine should attempt to fulfill these requirements. In addition, saving in cost of operation, time, labor and energy are other advantages to be derived from use of improved machinery for such operations.

The project or prototype named "seed sowing cart", is a self developed and indigenous product and designed in such a manner so that the disadvantages of other machines available in the market is overcome.

On other hand, other cheaper seed sowing machine which are available in market are technically uncomfortable. Also the seed sowing machines available in the market are not capable enough to carry out sowing operation consistently.

Secondly, during the end of the process, there are chances of seeds falling off the hopper and it is highly undesirable. Such machines cannot be managed by the hands of farmers themselves.

## I. RESEARCH

### EXISTING METHODS OF TACKLING THE PROBLEM:

Farmers have been using traditional and conventional method of sowing seeds. In conventional method the farmer has to bend and sow the seeds and walk throughout the farm many times which led to severe back injuries and joint injuries, musculoskeletal disorders. This method is extremely laborious and leads to several life-time injuries and problems for farmers.

There are two types of conventional method for sowing the seed:-

1. Marking process-
2. Sowing process-

**MARKING PROCESS:** - In this process first the field is cleared, and then the cart is moved in the field. Then the hardness of the field is removed and after the rain came and again the plugging moved in the field. Then the marking process is done as follows:

1. It requires two labors for marking the field of 1 acre.
2. It requires 8 hours for doing this job and charges 800/- per day.

#### DRAWBACKS:-

If 2 labors requires 8 hrs. To plough the field then for ten acre 20 labors are required which is very expensive. And maximum expensive cost is about 8000/- just to mark the field and the labors suffers from back pain, neck pain, musculoskeletal disorder and carpal tunnel syndrome.

#### SOWING PROCESS:-

In this process the seed is sowed by the labors itself by their own hand. The seed is sowed in the marking part and the again the field ploughed by the cart.

#### DRAWBACKS:-

Again the drawbacks are same such as high labor cost. Muscular problems including neck pain, back pain, different types of muscles related disorders, etc

## II. LIMITATIONS OF EXISTING MACHINES

1. The Weight of the Machine is more.
2. Available for Tractors drive.
3. No Arrangement for depth control.
4. No Arrangement for seed bed preparation.
5. Improper compaction of soil over furrows.
6. Adjustment of row spacing is improper.
7. The cost of machine is more

## III. DESIGN CALCULATIONS

### 1. Design of Shank

Let,

$b \times h$  = Shank cross-section,  $\text{mm}^2$

$l$  = length of breast of shovel

$R$  = Radius of curvature of bent portion of shovel ( $R \leq 120$  mm) -----Dubey (1985)

$h_1$  = Height of shank from its tip to the bent portion, mm

$d$  - Maximum operating depth, mm

$H_1$  = Shank height from the frame to the top end of the breast, mm

$H$  = Height of shank from the tip of shovel to the frame, mm

$\alpha$  = Rake angle, deg

$\Delta H$  = Length of the upper part of tine serving for fastening, cm

$K_o = \text{Soil Resistance, kg/cm}^2$

From the geometry, the radius of curvature 'R' of the bent portion of the shovel is given by

Values of  $h_1$ ,  $l$  &  $\alpha$  have been taken on the basis of research findings by Dubey (1985)

$h_1$  – 150 mm

$l$  – 120 mm

$\alpha$  -  $30^\circ$  -----(Siemens et al(1965) conclude analytically as well as from experimental results, that a rake angle of furrow opener of  $30^\circ$  gave minimum draft )

Force exert on the opener is

$$D = K_o \times w \times d$$

Where,

$D$  – Draft force, Kgf

$K_o$  - Specific Soil Resistance –  $0.25 \text{ kg/cm}^2$  Source Dubey 2003

Take  $K_o$  - 3 times higher as a factor of safety

$w$  – Width of opener, cm

$d$  - Depth of opener, cm

Take  $w$  – 2.5 cm ..... (Available in the market)

$d$  - 10 cm

$$D = K_o \times w \times d$$

$$= 3 \times 0.25 \times 2.5 \times 10$$

$$= 18.75 \text{ Kgf}$$

Take factor of safety – 3

$$D = 3 \times 18.75 = 56.25 \text{ Kgf (Total draft)}$$

Maximum bending moment for a cantilever length of 37 cm length

Bending moment (M) = draft (kgf) x Length of shank (cm)

$$M = 56.25 \times 37 = 2081 \text{ kgf-cm}$$

We Know that

$$\sigma = \frac{MC}{I}$$

$\sigma$  = Bending stress, kgf/cm<sup>2</sup>

M = Bending Moment, kgf-cm

C = distance from the natural axis to the point at which stress is determined, cm

I = Moment of inertia of the rectangular section, mm<sup>4</sup>

The section modulus axis was computed by using the formula

$$Z = \frac{I}{C}$$

$$Z = \frac{M}{\sigma}$$

For M.S rectangular section

$$\sigma = 1000 \text{ kgf/cm}^2$$

$$Z = \frac{2081}{1000}$$

$$Z = 2.081 \text{ cm}^3$$

$$Z = \frac{bh^2}{6}$$

Assume ratio of thickness to width of tine, b: h = 1:2

b = 14.6 mm

Take thickness b = 16 mm ..... (Availability of standard size)

Width = 2 x 16 = 32 mm

This section would yield a maximum fluctuation

$$Y_{max} = \frac{DL^4}{3EI}$$

For M.S. material

$$E = 2 \times 10^4$$

$$I = \frac{bh^2}{12}$$

$$I = \frac{16 \times 32 \times 32}{12}$$

$$I = 1365.3 \text{ mm}^4$$

$$Y = \frac{56.25 \times 370^4}{3 \times 1365.33 \times 2 \times 10^4}$$

$$Y = 1.06 \text{ mm}$$

Hence, there is a less deflection in the shank for a length of 370 mm as compared to the other lengths.

## 2. Design of Base Frame

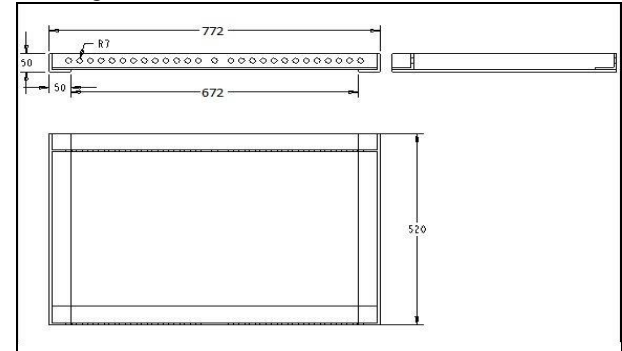

Fig 1. Base Frame

Length of the base-frame- 760 mm

Width of the Base-frame – 520 mm

- a. Gupta, *et al.* (1970)[10] at Punjab observed significantly higher grain yield of wheat due to wider row spacing (22.5 cm) as compared to normal sowing (15 cm) both under timely and late sown situation under rain fed condition on loamy sand soils.
- b. At Pantnagar (UP) on silty clay loam soils, wide row spacing (23 cm) caused for significant enhancement in wheat grain yield (5535 kg/ha) than normal sowing of 15 cm (5418 kg/ha). This was attributed to increased number of grains per spike (Sharma and Mahendra Singh, 1971)[11].
- c. Thakur *et al.* (1974) on medium black soil reported that wider row spacing (25 cm) resulted in increased number of grains per ear, test weight and grain yield of wheat as compared to normal method of sowing at 15 cm row spacing under rain fed condition.

## 3. Design of Linear Distance between consecutive seeds

Let,

D1= Diameter of gear 1.=36mm

D2= Diameter of gear 2.=80mm

D3=Diameter of gear 3 = 36mm

D4= Diameter of gear 4 = 80mm

Df = Diameter of fluted roller =35mm.

T1= No of teeth of gear 1.

T2= No of teeth of gear 2.

T3=No of teeth of gear 3.

T4= No of teeth of gear 4.

N1=speed of gear 1 in rpm.

N2= speed of gear 2 in rpm.  
N3= speed of gear 3 in rpm.  
N4= speed of gear 4 in rpm.  
V1= Average Linear velocity of bullock cart in m/sec.

The Average Linear Velocity of Bullock Cart is between 1.5 to 2mph

$$V1 = 2.5 \text{ km/hr.}$$

$$V1 = 0.7 \text{ m/sec}$$

Therefore, Speed of Small Gear (N1)

$$V1 = \frac{\pi D1 N1}{60}$$

$$0.7 = \frac{\pi \times 0.036 \times N1}{60}$$

$$N1 = 371.55 \text{ rpm.}$$

Therefore Velocity Ratio

$$\frac{N2}{N1} = \frac{D1}{D2}$$

$$\frac{N2}{371.55} = \frac{36}{80}$$

$$N2 = 167.19 \text{ rpm}$$

We Have N2 = N3 = 167.19rpm (since they are mounted on same shaft.)

Now, Velocity ratio

$$\frac{N4}{N3} = \frac{D3}{D4}$$

$$\frac{N4}{167.19} = \frac{36}{80}$$

$$N4 = 75.23 \text{ rpm}$$

Also N4 = Ns (since mounted on same shaft.)

Since the linear velocity of bullock cart is 0.7m/sec

Amount of Distance Cart and Seeder travelling in one sec = 0.7m.

No of Revolution of fluted roller in one sec = 1.25.

No of Teeth on the periphery of fluted roller = 10 nos.

Therefore, Linear Distance between consecutive seeds =

$$\frac{0.7}{1.25 \times 10}$$

Linear Distance between consecutive seeds = 5.6 cm.

Similarly, linear distance between seeds can be altered by changing the diameter of Gear 3

Table1. Value of Gear Diameter for different linear distance between seeds

S.No	Linear Distance between seeds	Diameter of Gear 3
1	5.5 cm	36 mm
2	3 cm	100.5 mm
3	2 cm	67 mm

#### 4. Seed Metering Device

The seed metering device used in the machine is Fluted Roller type. Fluted roller metering mechanism is a more positive metering device. Axial or helical flutes are machined or cast on an aluminium, cast iron or plastic roller. Rotation of fluted roller in housing, filled with seeds, causes the seeds to flow out from roller housing in a continuous stream. Seed rate is controlled by changing exposed length of fluted roller in contact with seeds and fairly accurate seed rate can be achieved.

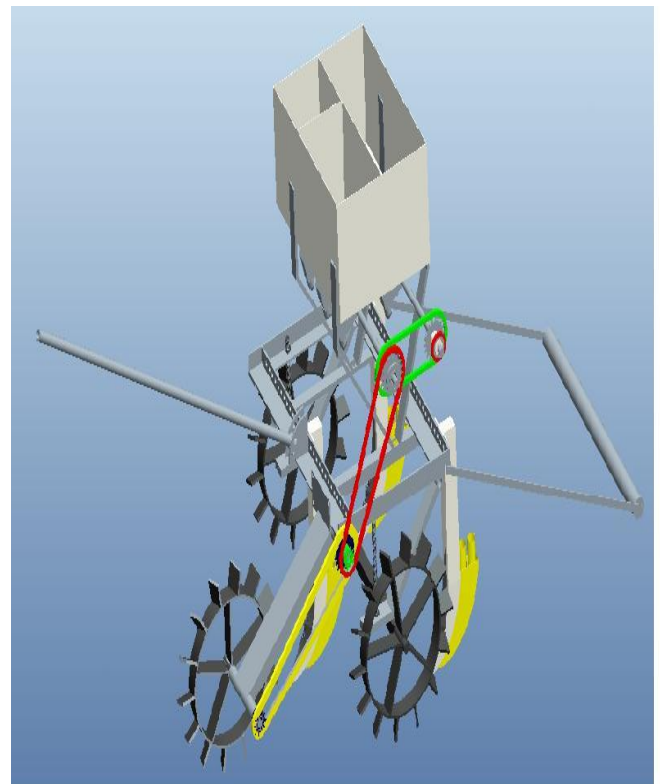

Fig 2. CAD Model of Designed Machine in Creo 2.0

IV. MAIN COMPONENTS OF DESIGNED MACHINE

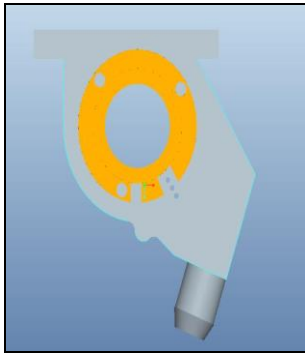

Fig 3. Seed Cup With Fluted Roller

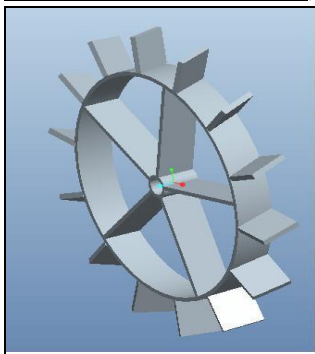

Fig 4. Base Wheel

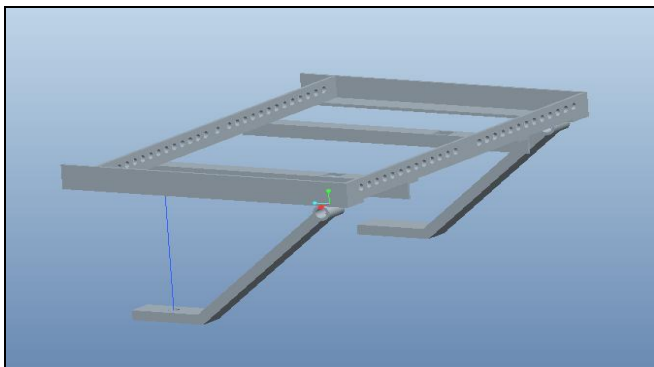

Fig 5. Base Frame

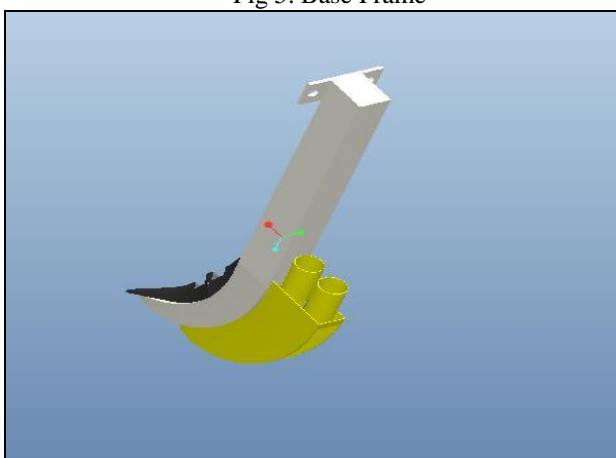

Fig 6. Furrow Assembly

V. SPECIAL FEATURES OF DESIGNED MACHINE

1. Width Control (Displacement along X Axis)

The proper width between rows is to be maintained to achieve the best yield. Also different types of seeds require different width between rows in order to achieve best yield. The base frame is so designed so that the furrow assembly can be assembled at different location on the base frame resulting in change of width between rows of seed, enabling use of seed drill for variety of seeds.

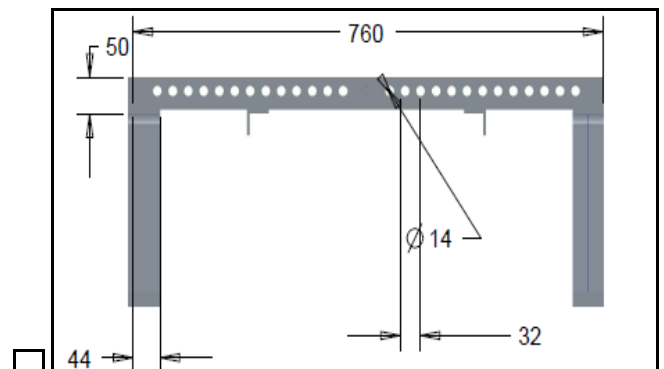

Fig 7. Front View of Base Frame

2. Depth Control (Displacement along Y Axis)

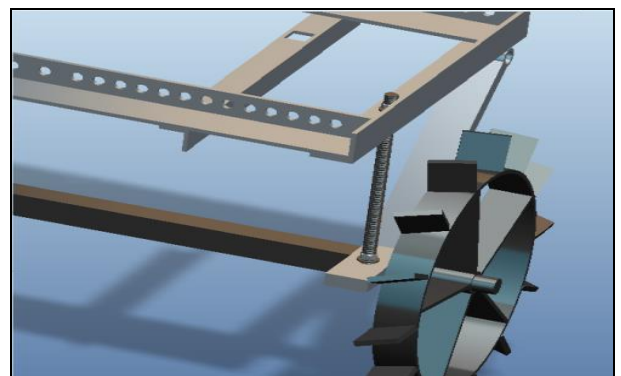

Fig 8. Depth Control Arrangement

The proper depth of seed and fertilizer needs to be maintained for the proper germination of the seeds. The depth of seed and fertilizer is controlled with the help of a stud on which four numbers of Nuts are given to control the depth. The seeds are to be sown at a depth of 2-3 cm and fertilizer to be placed at a depth of 3-4 cm. The depth control arrangement controls the depth of the seed and fertilizer.

3. Control of Linear Distance between seeds (Displacement along Z Axis)

The Linear Distance between seeds can be altered according to different seeds by changing the diameter of gear 3, different distances of 2cm, 3cm; 4cm, 5cm, etc can be achieved by altering the gear simply.

## VI. CONCLUSION

The proposed design of machine is economical to fabricate, and have greater design simplicity than its counterpart, with proper seed placement at desired depth, distance between rows with special feature to alter linear distance between seeds, proper spreading of fertilizer and compaction of soil. The fabrication and production of this design will lead to fulfillment of desired aims and objectives of a local farmer

## REFERENCES

1. E. Soza, G. Botta, M. Tourn, 2004, "Sowing efficiency of two sowing machines with different metering devices and distribution system", Spanish Journal of Agricultural research 2(3), 315-321
2. P. P. Shelke, 2011, "Frontline demonstration on bullock-drawn planter enhances yield of soyabean crop", International Journal of farm Sciences 123-128.
3. Umed Ali Soomro, Mujeeb Ur Rahman, Ejaz Ali Odhno, Sheeen Gul, Abdul Qadir Tareen, 2009, "Effects of sowing Method and seed rate on Growth and yield Of Wheat", World Journal of Agricultural Sciences 5(2):159-162
4. N. Iqbal, N. Akbar, M. Ali, M. Sattar and L. Ali, 2010, "Effect of Seed rate and row spacing on yield and yield components of wheat", Journal of Agricultural Research, 48(2)
5. Abu Elgasim. A. K and Abusuwar. A. O, 2011, "Effect of sowing methods, Seeding Rates and Cutting Management on seed yield of Wheat", International Journal of science and Nature 2(3):570-574
6. Hari Ram and Guriqbal Singh, 2011, "Growth and seed yield of sunnhemp Genotypes as Influenced by Different sowing methods and seed rates", World Journal of Agricultural Sciences 7(1):109-112
7. A. U. Malik, M. Ahmad and I. Hussain, 2009, "Effect of seed rates sown on different dates on wheat under agro-ecological conditions of Dera Ghazi Khan", The Journal of Animal And Plant Sciences 19(3)
8. Gupta. V. K, Vig. A. C and Ranjodh Singh, "Influence of spacing, time of sowing and nitrogen fertilization on the yield of wheat" Indian Journal of Agronomy. 15:251-253.